

The Potting Shed

This charming potting shed opens the mind of the gardener in all of us! Beyond the French doors bask in sunshine and all wonderful things from the garden. Birds, bees and butterflies are intertwined in the flowers and vines that surround this heavenly spot!



Finished size about 52 1/2"

Copyright © 2019 Claudia Dinnell

All rights reserved. No part of this may be reproduced in any form or by any means without written permission from the copyright holder. These designs & instructions are for personal non-commercial use by the original purchaser only and are protected under US & International Laws.

The Potting Shed Supply List

Finished size about 52 1/2"

Design: **The Potting Shed** \$90.00 (each student must purchase the design to attend the workshop)

Fabric Supply List:

- 3 yards Light colored tone on tone Background Fabric
- 1 3/4 yards Inner & Outer Border Fabric **(Not needed in class)**
- 1/4 yard **Optional:** Quarter Inch Border Fabric surrounding the center
- 6 1/2 yards Fusible Woven Interfacing by OESD or Shape Flex 101 by Pellon (20" wide)
- 1/2 yard Binding **(Not needed in class)**
- 4 yards Backing **(Not needed in class)**
- 60" x 60" Batting **(Not needed in class)**

Embroidery Supply List:

Hoop Requirements: stitch field must be 8" wide x 12" high or **larger** / bring your largest hoop & grid
All Hoops must have a **grid/template** (you would want to make one if you don't have one)

15 yards Heavy Weight Tear Away (Pellon #806 Stitch & Tear)

Temporary Adhesive Spray: Suggested 505 or Mettler Web Bond 101 Spray Adhesive

Removable fabric marking pen (No air erasable pens)

Embroidery Needles 80/12 and 90/14 (both work but some machines prefer one over the other)

Terrial Magic Starch (mandatory)

18"x24" Wool Ironing pad suggested

Basic embroidery kit including small double curved scissors, tweezers, **Jumbo Wonder Clips**, Arrow shaped post it notes by Post-It-Notes (they say: **SIGN HERE**)



Bobbin Thread: (light neutral color & black)

Embroidery Thread: Isacord 40 wt. Embroidery Threads listed

Browns

- 0933 Redwood
- 1134 Light Cocoa
- 1123 Carmel Cream
- 1154 Penny

Golds & Yellow

- 0824 Liberty Gold
- 0700 Bright Yellow

Blues

- 3713 Cornflower
- 3920 Chicory

Greens

- 6043 Yellowgreen
- 5722 Green Grass
- 5730 Apple Green
- 5933 Grasshopper

Greys

- 0142 Sterling
- 2674 Steel

Purples

- 2910 Grape
- 2830 Wild Iris

Pink/Reds

- 1904 Cardinal
- 2320 Raspberry
- 2152 Heather Pink

Terracotta Pots

- 0932 Nutmeg
- 1430 Melon
- 1311 Date

Black & White

- 0020 Black
- 0015 White

Sewing Supply List

50wt. Cotton Thread matching the fabric for piecing **(not needed in class)**

Basic sewing kit including scissors, pins, rotary cutter & mat, long straight ruler, etc. **(not needed in class)**

20 1/2" Square Ruler by Creative Grids for accurate marking & trimming

Copyright © 2019 Claudia Dinnell

All rights reserved. No part of this may be reproduced in any form or by any means without written permission from the copyright holder. These designs & instructions are for personal non-commercial use by the original purchaser only and are protected under US & International Laws.

www.claudiascreationsaz.com

TIPS FOR SUCCESSFUL EMBROIDERY!

Keep these pages accessible, you will need to refer to these “Tips” throughout your embroidery!!
Follow Claudia’s two step “**Perfect Placement Technique**” for accurately multi-hooping large designs!

Step #1: Marking the design’s first stitch location on the grid:

- Attach the **hoop and grid** to the module with no fabric.
- **Open the design** to be embroidered.
- Advance to the **embroidery sewing screen**. Embroidery Machines open a design in an editing screen. Touch the icon that moves you to the embroidery sewing screen. Advancing to the embroidery sewing screen takes you to the first stitch of the design, where you are ready to embroider!

Brother, Babylock, Janome, and Singer machines have an automatic center stitch programmed into the machine. You must advance past this “programmed center stitch” to move to the first stitch of my designs. These machines will have an additional icon (usually a +/- key) you will need to touch to move you to first stitch of my design.

Bernina machines with a Basting Box option must make sure the built in basting box option is turned off before they advance to the embroidery sewing screen.

- By hand, lower your needle to touch the grid. Place an arrow shaped post-it-note on the grid so the tip of the arrow touches the tip of the needle. (See picture) This marks the first stitch location of my design on the grid (not the center of the design, not the center of the hoop, but the first stitch of the opened design).
- Raise the needle; remove the hoop and the marked grid from the module.

Step #2: Hooping the Fabric

- Place the **inner hoop with the grid** on the (stabilized and marked) background fabric. The arrow shaped post-it-note on the grid should be pointing to either the **Needle Alignment** or to the **Placement Line** location on the background fabric. The location is noted in the Embroidery Instructions and will be different for each hooping (it will almost never be the center of the hoop).
- Hoop the (stabilized and marked) fabric with the lines on the grid parallel and perpendicular to the drawn lines on the fabric. The drawn lines need not lie exactly under the lines of the grid, but must be parallel and perpendicular to the lines on the grid. This keeps the larger piece of fabric square and straight as you embroider.
- Remove the grid from the hoop and attach the hoop to the module.
- It may be necessary to re-position the needle exactly over the **mark** indicated in the instructions. Use your Move Motif Icon to tweak the needle perfectly over the mark.
- **Needle Alignment** is to place the needle over a specific mark like the drawn crosshair on the fabric
- **Placement Line** is to sew (without thread) over previously sewn stitches to ensure correct placement.
- To watch a demo of the “Perfect Placement Technique” from your computer go to:
www.claudiascreationsaz.com Select the “Videos” tab and choose Perfect Placement.

Additional Tips and Helps!

Tip #1: Built in Basting Box!

Many embroidery machines have a built-in basting box option. When this option is enabled it may add a color stop to the stitching order of the design. This option should be disabled before opening a design. If the basting box option is on or enabled when you advance to the embroidery sewing screen, you would be marking the grid with the first stitch position for the basting box and not the first stitch of the design! Be sure to disable the basting box option before opening a design. Mark the first stitch of the design with the post-it note arrow.

Copyright © 2019 Claudia Dinnell

All rights reserved. No part of this may be reproduced in any form or by any means without written permission from the copyright holder. These designs & instructions are for personal non-commercial use by the original purchaser only and are protected under US & International Laws.

www.claudiascreationsaz.com

Tip #2: Hooping Tips

I place sections of **permanent** double sided tape (**not repositionable**) on the wrong side of the inner hoop. Then I flip the inner hoop right side up and place the inner hoop, with the grid inside of it, on the fabric. The doubled sided tape holds the inner hoop to the fabric. This makes it easier to pick up the inner hoop and fabric and place it in the outer hoop with ease. (Always loosen the outer hoop screws as much as possible). Remove the tear away stabilizer from the last hooping to reduce the stabilizer "bulk". Roll the excess fabric in a tube shape and use clips to hold the excess fabric out of the way. This will prevent the fabric from accidentally catching under the hoop.

Tip #3: Unusual Embroidery Instructions:

Needle Alignment: This is placed first in the stitching order to align the needle exactly where it goes.

It is strictly for needle placement and not to be sewn out (unless indicated). If it is accidentally sewn out it will look like a crosshair. Pick it out!

Placement Line: This is a line that is to be sewn out without thread over an existing line to ensure correct placement. It is an alignment tool for connecting one hooping to another.

The blank line after the thread color: Thread Purple # _____ (Write your thread Color # on the line) It will help you remember what color you used when you return to embroidering.

Tip #4: Ironing/Pressing

Place the embroidered background fabric **wrong side up**, over a wool mat. Padding the stitches with a wool mat won't crush them. I usually spray with starch and then press the fabric.

Tip #5: Trimming the Blocks

For best accuracy, use a square ruler to trim all the blocks. Place the square ruler on the block lining up two sides, then trim. Trimming with a 6" x 24" ruler is not as accurate and leads to slips and miss-cuts. If you have difficulty keeping a ruler from moving when you cut, place double sided tape on the side that goes against the fabric! Also, using quilting gloves helps to hold it in place!

Tip #6 Sewing without Thread

Every machine has a icon where you can advance or move backwards through a design. This is usually used when you "**break a needle**" or "**run out of bobbin thread**" and you need to backup to replace stitches. I use this icon to advance through a design to "**sew without thread.**" As you advance drop the needle often to check the position to be sure you are correctly following the placement line. **YouTube/ claudiascreationsaz for demo.**

Fabric Preparation

Removing Dye:

Usually I do not wash my fabrics before embroidering or piecing them into a quilt. However, if I am using darks I may want to test a piece to see if it is color fast. If it is not, you may want to treat the fabric with a product that will remove the excess dye. Products like Retayne and Synthrapol always work great.

Woven Interfacing:

First steam iron and starch the fabric. Then place the woven interfacing (Fusible Woven by OESD or Shape Flex 101 by Pellon) adhesive side down, on the wrong side of the fabric. Spray with water to activate the adhesive. Use your hands to smooth out the moistened Interfacing over the fabric before using the steam iron. Set the steam iron on the center area and hold the iron long enough to dry & seal the two layers together, but not so long that it burns! Pick up the iron and place it close to the first spot. Repeat until all the interfacing is sealed to the fabric. This will "pre-shrink" both fabric and interfacing. The Interfacing will shrink, that is expected. All the edges of the Interfacing should be sealed to the fabric as if they were one piece so they can't be separated.

Copyright © 2019 Claudia Dinnell

All rights reserved. No part of this may be reproduced in any form or by any means without written permission from the copyright holder. These designs & instructions are for personal non-commercial use by the original purchaser only and are protected under US & International Laws.

www.claudiascreationsaz.com

Cutting Instructions

Background Fabric: (3 yards)

Cut (1) 44" strip off the fabric
It will be a 44" square.

Cut (2) 22"x Length of Fabric (64")
Cut down the long **center** of the **length** of the fabric.
The width will be 22"+/- depending on the width of your fabric.

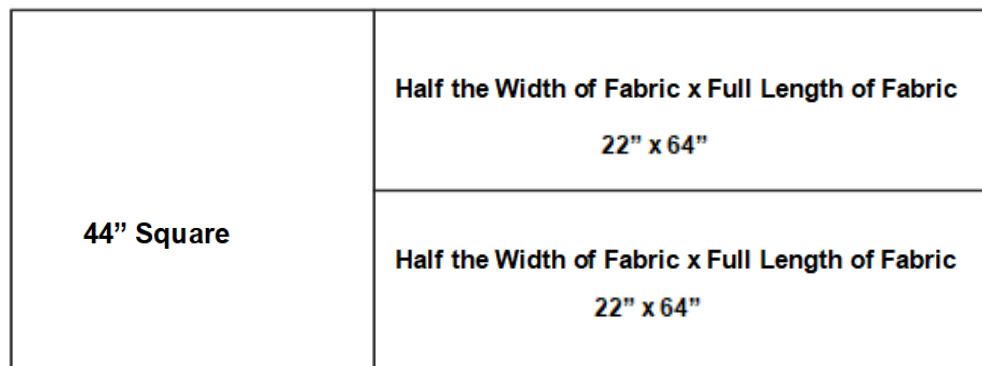

Fabric Preparation

Terial Magic.

Saturate the background fabric (shown above) in **Terial Magic**. Spray or pour onto the fabric to saturate. This product is a heavy starch. The fabric must be very stiff to avoid stretching during embroidery. Let the fabric almost dry then iron the fabric flat and smooth. (YouTube channel / claudiascreationsaz)

Interfacing: Shape Flex 101 by Pellon or Fusible Woven by OESD

Center and Iron interfacing (after Terial Magic) to the back of the 44" Block. Piece the interfacing to get the size needed. Over lap the pieced sections by 1/2". The interfacing may be smaller than the fabric blocks & it will shrink when you iron it. Lightly spray with water to activate the adhesive. Smooth the interfacing with your hands (this will help to displace the air between the interfacing & fabric).

Start pressing in the center and work out slowly. Iron the interfacing to the fabric. All edges should be sealed together. If you see air bubbles, spray with water and iron again. Watch my Fabric Prep video for a demo.

(www.claudiascreationsaz.com / Videos / Fabric Prep or YouTube / claudiascreationsaz / Fabric Prep)

Marking Instructions

Mark the Fabric:

On the front side of the fabric (pen with removable ink) mark a **horizontal & vertical line, centered on the fabric** (aka=center crosshair / shown in red) use a square ruler to mark the lines to ensure a 90° center. See my YouTube demo.

YouTube / ClaudiasCreationsaz / Marking the Fabric (be sure to subscribe & click on the bell to be notified of new videos)

Mark **vertical lines 6" & 12"** on both sides of the **Center Vertical Line**. Mark **horizontal lines 6" & 12"** above & below the **Center Horizontal Line**. The lines must be **parallel & perpendicular** to each other (90° angles). These lines only need to be 24" long: use a 6x24" ruler.

Write the words "**Top of the Fabric**" at the top of the fabric.

The markings only need to be the length of your 24" ruler.

Be sure to center the ruler on the fabric. See diagram. 

Additional cutting & marking instructions will follow as you need them.

Bring the prepared center block to class.

This is the only fabric needed for class.

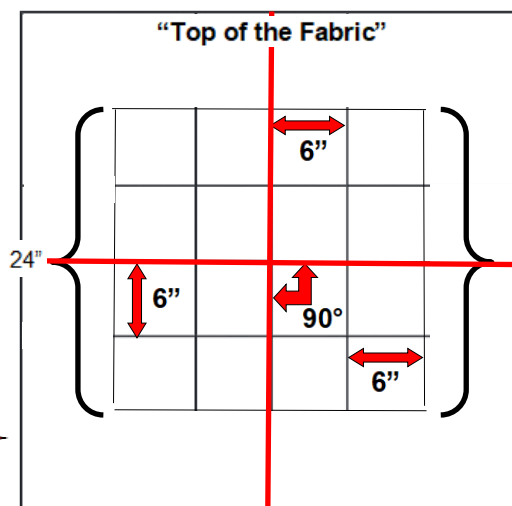

Copyright © 2019 Claudia Dinnell

All rights reserved. No part of this may be reproduced in any form or by any means without written permission from the copyright holder. These designs & instructions are for personal non-commercial use by the original purchaser only and are protected under US & International Laws.

Center Motif

Select the folder with the format your machine reads/ Select **#1 Center Motif** folder.

Select the prepared Background Fabric.

Hooping #1 Bench & Bunny

Attach the hoop and the grid (no fabric) to the module.

Open #1 Bench & Bunny

Step #1 Advance to the **embroidery sewing screen** to go to the 1st stitch of the design.

Step #2 Lower the needle, lay an arrow shaped post it note on the grid with the tip of the arrow touching the needle. (The arrow is positioned about 3" above center & slightly to the left of center on the grid)

(Refer to "Tips for Successful Embroidery" & pay attention to info about getting to the 1st stitch of the design for **Brother**, **Babylock**, & **Janome** machines)

Fabric Position: To hoop this design the **Top of the Fabric** is **rotated** to the right of the hoop.

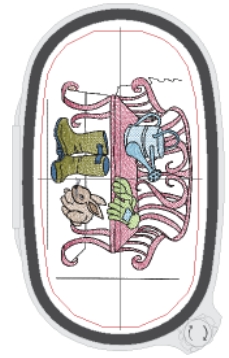
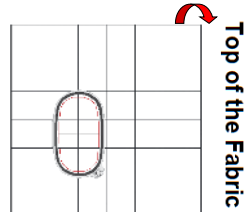

Hoop the fabric with the **arrow on the grid pointing to the crosshair 6" to the left of center on the rotated FABRIC**. See **Example #1**. The drawn lines on the fabric must be parallel and perpendicular to the lines on the grid.

Remove the grid from the hoop and attach the hoop to the module.

Float two pieces of tear away stabilizer (sprayed with 505) **under the attached hoop**.

Thread Color #1 **Placement Line**. The fabric is rotated to the right. The needle is positioned over the crosshair **6" to the left of center** on the rotated fabric. See green start arrow in **Example #1**. Sew Color #1 without thread: **it starts at the crosshair & sews downward 6" following the line you drew**. (Path shown in red)
Advance to **Color #2**.

Thread Color #2 **Raspberry (2320) # _____**
Embroider the bench.

Thread Color #3 **Apple Green (5730) # _____**
Embroider the gloves.

Thread Color #4 **Chicory (3920) # _____**
Embroider the watering can & patch on gloves.

Thread Color #5 **Yellowgreen (6043) # _____**
Embroider the outer part of the boots.

Thread Color #6 **Cornflower Blue (3713) # _____**
Embroider inside of boots, bottom and buckle of boots.

Thread Color #7 **Date (1311) # _____**
Embroider the little section of a pot next to bench leg.

Thread Color #8 **Carmel Cream (1123) # _____**
Embroider the bunny.

Thread Color #9 **Steel (2674) # _____**
Embroider the whiskers.

Thread Color #10 **Black (0020) # _____**
Embroider the outlining.

Thread Color #11 **White (0015) # _____**
Embroider the white of the bunny's eye.

Remove the hoop from the module and the fabric from the hoop.

Gently remove the stabilizer from the back.

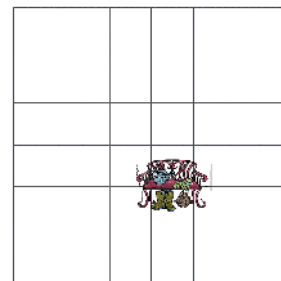
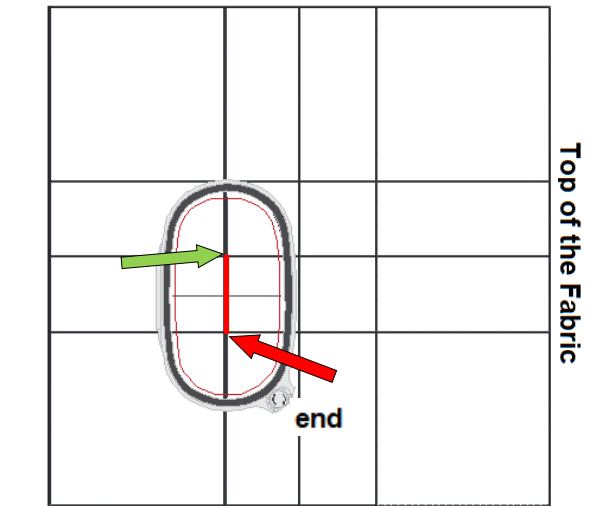

Copyright © 2019 Claudia Dinnell

All rights reserved. No part of this may be reproduced in any form or by any means without written permission from the copyright holder. These designs & instructions are for personal non-commercial use by the original purchaser only and are protected under US & International Laws.

Hooping #2 Pots & Shovels

Attach the hoop and the grid (no fabric) to the module.

Open #2 Pots & Shovels

Step #1 Advance to the **embroidery sewing screen** to go to the 1st stitch of the design.

Step #2 Lower the needle, lay an arrow shaped post it note on the grid with the tip of the arrow touching the needle. **(The arrow is positioned about 1 1/2" above and 2 1/2" to the right of center on the grid)**

(Refer to "Tips for Successful Embroidery" & pay attention to info about getting to the 1st stitch of the design for Brother, Babylock, & Janome machines)

Fabric Position:

To hoop this design the **Top of the Fabric** is positioned at the top of the hoop.

Top of the Fabric

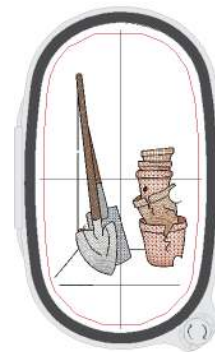
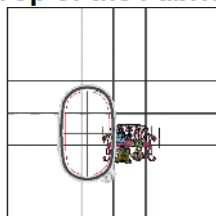

Hoop the fabric with the **arrow on the grid pointing to the green start arrow** see **Example #2**. The drawn lines on the fabric must be parallel and perpendicular to the lines on the grid. Remove the grid from the hoop and attach the hoop to the module. **Float two pieces of tear away stabilizer** (sprayed with 505) **under the attached hoop**.

No Thread Color #1 **Placement Line**. The needle is positioned at the green start arrow.

See green arrow in **Example #2**.

Sew Color #1 without thread: it sews from the start arrow downward to the end arrow following the stitched in black line. (Placement Line shown in red) Re-position if needed to follow the line. Advance to **Color #2**.

Thread Color #2 **Date (1311) #** _____

Embroider three of the pots.

Thread Color #3 **Sterling (0142) #** _____

Embroider the front shovel blade and back metal shaft.

Thread Color #4 **Nutmeg (0932) #** _____

Embroider the remaining two pots.

Thread Color #5 **Cardinal (1904) #** _____

Embroider the lady bug.

Thread Color #6 **Light Cocoa (1134) #** _____

Embroider the back shovel handle.

Thread Color #7 **Steel (2674) #** _____

Embroider the back shovel blade.

Thread Color #8 **Redwood (0933) #** _____

Embroider the front wood handle on the shovel.

Thread Color #9 **Black or Gray (0020 or 2674) I prefer Black**

Embroider the spider.

Thread Color #10 **Black (0020) #** _____

Embroider the outlining.

Remove the hoop from the module and the fabric from the hoop.

Gently remove the stabilizer from the back.

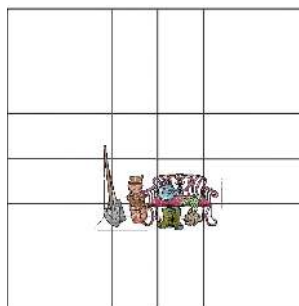

Example #2.

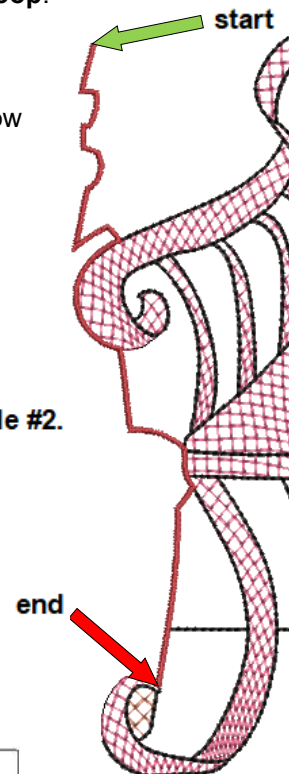

Copyright © 2019 Claudia Dinnell

All rights reserved. No part of this may be reproduced in any form or by any means without written permission from the copyright holder. These designs & instructions are for personal non-commercial use by the original purchaser only and are protected under US & International Laws.

Hooping #3 Flower Boxes

Attach the hoop and the grid (no fabric) to the module.

Open #3 Flower Boxes

Step #1 Advance to the **embroidery sewing screen** to go to the 1st stitch of the design.

Step #2 Lower the needle, lay an arrow shaped post it note on the grid with the tip of the arrow touching the needle.

(The arrow is positioned about 2" & 2" to the left of center on the grid)

Fabric Position: upside down

To hoop this design the **Top of the Fabric** is positioned at the **BOTTOM** of the hoop.

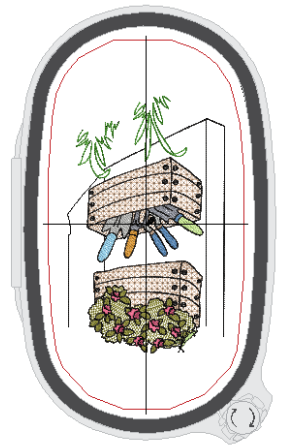

Hoop the fabric with the **arrow on the grid pointing to the green start arrow**.

See **Example #3**. The drawn lines on the fabric must be parallel and perpendicular to the lines on the grid.

Remove the grid from the hoop and attach the hoop to the module.

Float two pieces of tear away stabilizer (sprayed with 505) **under the attached hoop**.

No Thread Color #1 **Placement Line**. The needle is positioned at the green start.

See green start arrow in **Example #3**. Sew Color #1 without thread.

It sews from the start arrow upward to the end arrow following the stitched in black line (path shown in red). Re-position if needed.

Advance to **Color #2**.

Thread Color #2 **Carmel Cream (1123) # _____**
Embroider the two flower boxes.

Thread Color #3 **Chicory (3920) # _____**
Embroider the spade handle.

Thread Color #4 **Yellowgreen (6043) # _____**
Embroider the greenery in the top box.

Thread Color #5 **Raspberry (2320) # _____**
Embroider the flowers.

Thread Color #6 **Sterling (0142) # _____**
Embroider the screws & parts of the metal tools.

Thread Color #7 **Apple Green (5730) # _____**
Embroider the praying mantis and trowel handle.

Thread Color #8 **Liberty Gold (0824) # _____**
Embroider the fork handle.

Thread Color #9 **Steel (2674) # _____**
Embroider the remaining metal part of tools.

Thread Color #10 **Cornflower Blue (3713) # _____**
Embroider the clipper handle.

Thread Color #11 **Black (0020) # _____**
Embroider the outlining.

Thread Color #12 **Green Grass (5722) # _____**
Embroider the grass

Remove the hoop from the module and the fabric from the hoop.

Gently remove the stabilizer from the back

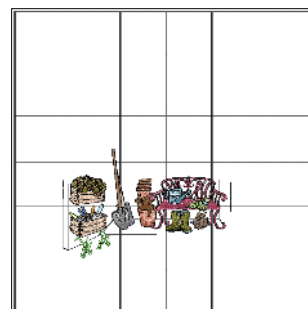
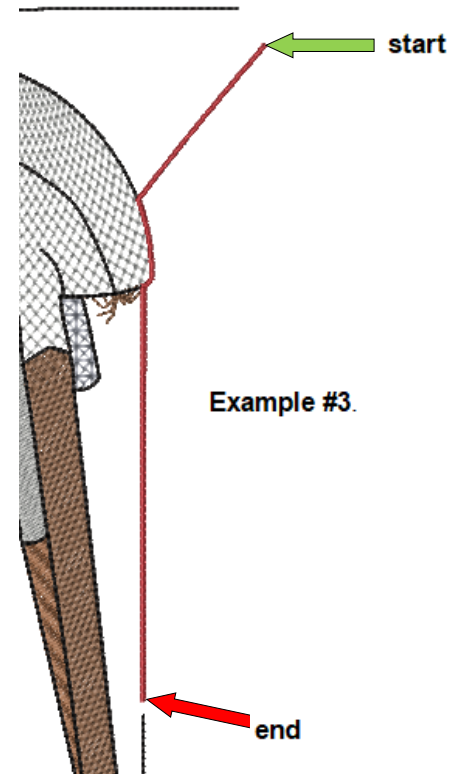

Copyright © 2019 Claudia Dinnell

All rights reserved. No part of this may be reproduced in any form or by any means without written permission from the copyright holder. These designs & instructions are for personal non-commercial use by the original purchaser only and are protected under US & International Laws.

Hooping #4 Hose

Attach the hoop and the grid (no fabric) to the module.

Note: Larger Hoops select **Combo Folder first design**, this will add #1 Lower Left Shutter to this hooping.
After #4 Hose follow page #16 for #1 Left Shutter thread colors.

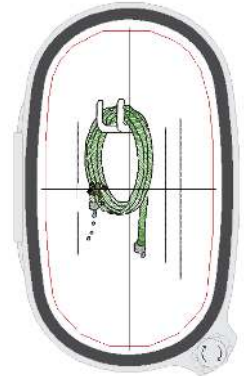
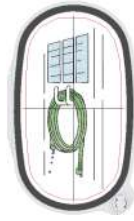

Open #4 Hose

Step #1 Advance to the **embroidery sewing screen** to go to the 1st stitch of the design.

Step #2 Lower the needle, lay an arrow shaped post it note on the grid with the tip of the arrow touching the needle. (The arrow is positioned about 3 1/2" above and 2 1/2" to the left of center on the grid.)

Top of the Fabric

Fabric Position:

To hoop this design the **Top of the Fabric** is positioned at the top of the hoop.

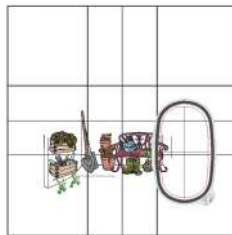

Hoop the fabric with the **arrow on the grid pointing to the green start arrow** see **Example #4**. The drawn lines on the fabric must be parallel and perpendicular to the lines on the grid. Remove the grid from the hoop and attach the hoop to the module. **Float two pieces of tear away stabilizer** (sprayed with 505) **under the attached hoop**.

No Thread Color #1 **Placement Line**. The needle is positioned at the green start arrow see **Example #4**. Sew Color #1 without thread
It sews from the start arrow downward to the end arrow following the stitched in black line (path shown in red).
Re-position if needed to follow the line. Advance to **Color #2**.

Thread Color #2 **Green Grass (5722) # _____**
Embroider the hose.

Thread Color #3 **Sterling (0142) # _____**
Embroider the hose head.

Thread Color #4 **Chicory (3920) # _____**
Embroider the water.

Thread Color #5 **Black (0020) # _____**
Embroider the outlining.

Thread Color #6 **Grasshopper (5933) or # _____**
Embroider the frog.

Thread Color #7 **Black (0020) # _____**
Embroider the outlining.

Remove the hoop from the module and the fabric from the hoop.
Gently remove the stabilizer from the back

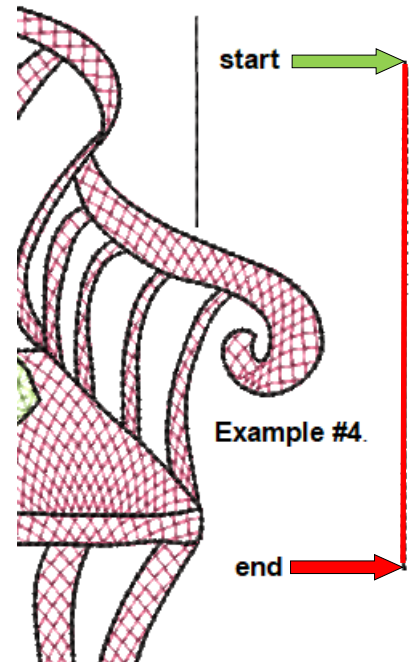
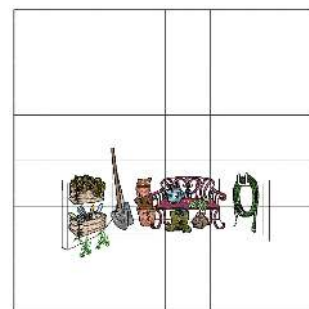

Copyright © 2019 Claudia Dinnell

All rights reserved. No part of this may be reproduced in any form or by any means without written permission from the copyright holder. These designs & instructions are for personal non-commercial use by the original purchaser only and are protected under US & International Laws.

Hooping #5 Stone Path

Attach the hoop and the grid (no fabric) to the module.

Open #5 Stone Path

Step #1 Advance to the **embroidery sewing screen** to go to the 1st stitch of the design.

Step #2 Lower the needle, lay an arrow shaped post it note on the grid with the tip of the arrow touching the needle. (The arrow is positioned about 5" below and 3" to the left of center on the grid)

Fabric Position:

To hoop this design the **Top of the Fabric** is rotated to the **LEFT** of the hoop.

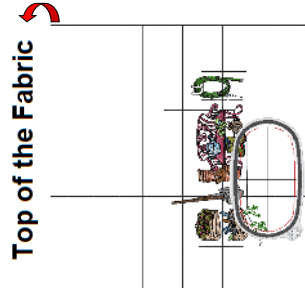
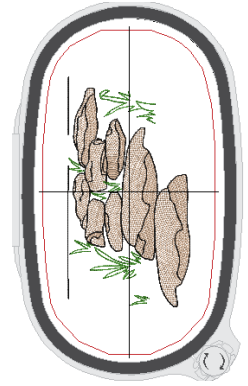

Hoop the fabric with the **arrow on the grid pointing to the green start arrow** see green start arrow in **Example #5**. The drawn lines on the fabric must be parallel and perpendicular to the lines on the grid. Remove the grid from the hoop and attach the hoop to the module. **Float one piece of tear away stabilizer** (sprayed with 505) **under the attached hoop**.

No Thread Color #1 **Needle Alignment**. The needle is positioned at the green start arrow see **Example #5**.

Sew Color #1 without thread. It sews from the green start arrow downward to the end arrow following the stitched in black line (path shown in red).

Re-position if needed to follow the line.

Advance to **Color #2**.

Thread Color #2 **Carmel Cream (1123) # _____**

Embroider the stones.

Thread Color #3 **Green Grass (5722) or # _____**

Embroider the grass.

Thread Color #4 **Black (0020) # _____**

Embroider the outlining.

Remove the hoop from the module

and the fabric from the hoop.

Gently remove the stabilizer from the back

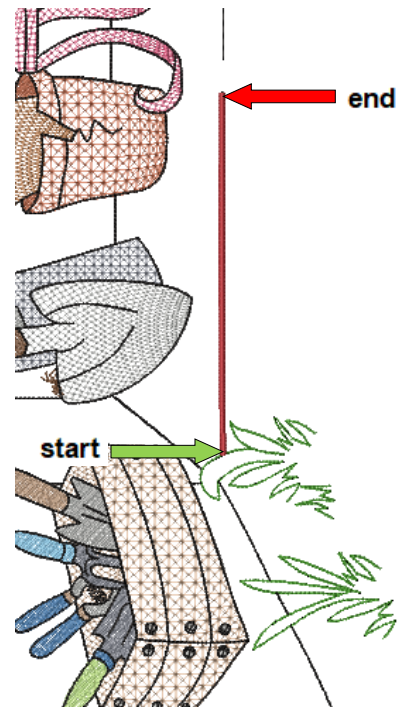
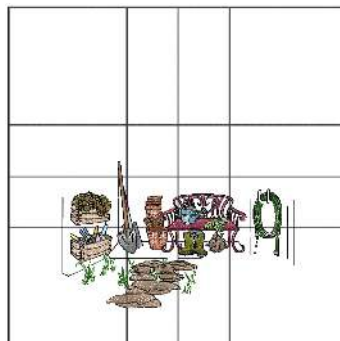

Example #5.

Copyright © 2019 Claudia Dinnell

All rights reserved. No part of this may be reproduced in any form or by any means without written permission from the copyright holder. These designs & instructions are for personal non-commercial use by the original purchaser only and are protected under US & International Laws.

Hooping #6 Grass

Attach the hoop and the grid (no fabric) to the module.

Open #6 Grass

Step #1 Advance to the **embroidery sewing screen** to go to the 1st stitch of the design.

Step #2 Lower the needle, lay an arrow shaped post it note on the grid with the tip of the arrow touching the needle. (The arrow is positioned about 3 1/2" below and 1 1/2" to the left of center on the grid)

Fabric Position:

To hoop this design the **Top of the Fabric** is rotated to the **LEFT** of the hoop.

Use a pen with removable ink: Draw a new floor line over the existing sewn in floor line: starting at the lower end by the shovels & continuing up to the wall line (by water drops). See **Example #6**. The line must be drawn straight and directly over the sewn in floor line. Line shown in red.

Hoop the fabric with the **arrow on the grid pointing to the green start arrow** See **Example #6**. The drawn lines on the fabric must be parallel and perpendicular to the lines on the grid. Remove the grid from the hoop and attach the hoop to the module. **Float one piece of tear away stabilizer** (sprayed with 505) **under the attached hoop**.

No Thread Color #1 Placement Line.

The needle is positioned at the green start arrow (end of the lower stitched-in floor line next to the grass), see **Example #6**.

Sew Color #1 without thread. It sews from the start arrow upward to the end arrow following the stitched in black line, passing the gap between the two embroidered lines and up the newly drawn line to the short wall line. (Placement Line shown in red.)

Re-position if needed to follow the line. Advance to **Color #2**.

Thread Color #2 **Green Grass (5722) # _____**
Embroider the grass.

Thread Color #3 **Black (0020) # _____**
Embroider the outlining.

Remove the hoop from the module and the fabric from the hoop.
Gently remove the stabilizer from the back

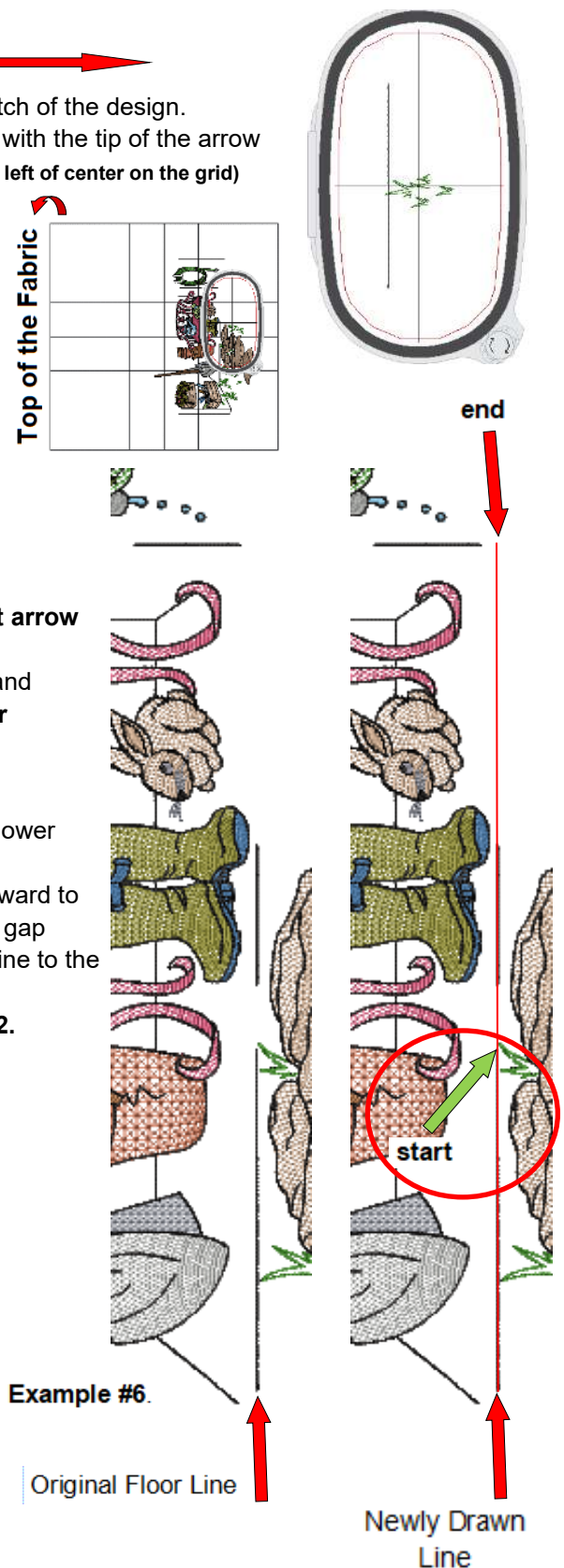
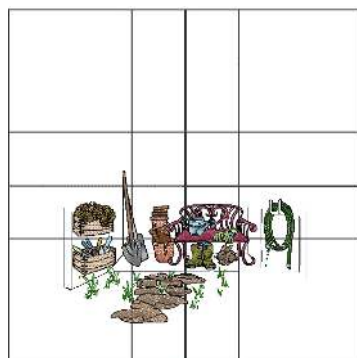

Copyright © 2019 Claudia Dinnell

All rights reserved. No part of this may be reproduced in any form or by any means without written permission from the copyright holder. These designs & instructions are for personal non-commercial use by the original purchaser only and are protected under US & International Laws.

Hooping #7 Beehive Shelf

Attach the hoop and the grid (no fabric) to the module. 

Open #7 Beehive Shelf

Step #1 Advance to the **embroidery sewing screen** to go to the 1st stitch of the design.

Step #2 Lower the needle, lay an arrow shaped post it note on the grid with the tip of the arrow touching the needle. (The arrow is positioned about 4" below & 3" to the right of center on the grid)

Fabric Position:

To hoop this design the **Top of the Fabric** is positioned at the top of the hoop. 

Use a pen with removable ink, extend the short line to the right of the bench **5" high (straight up)** parallel to the stitched in line & parallel to the previously drawn lines to ensure the straightness.

Top of the Fabric

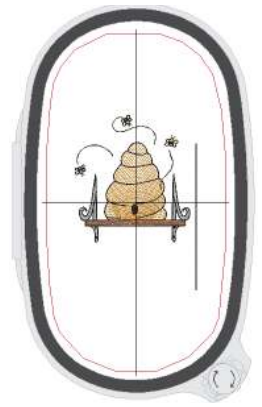
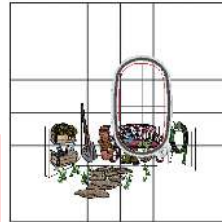

Hoop the fabric with the **arrow on the grid pointing to the green start arrow** see **Example #7**. The drawn lines on the fabric must be parallel and perpendicular to the lines on the grid. Remove the grid from the hoop and attach the hoop to the module. **Float two pieces of tear away stabilizer** (sprayed with 505) **under the attached hoop**.

Thread Color #1 Placement Line.

The needle is positioned at the green start arrow. See green arrow in **Example #7**.

Sew Color #1 without thread. It sews upward following the newly drawn line (path shown with red dotted line).

Advance to Color #2.

Thread Color #2 **Light Cocoa (1134)** # _____

Embroider the shelf.

Thread Color #3 **Bright Yellow (0700)** # _____

Embroider the bees.

Thread Color #4 **Liberty Gold (0824)** # _____

Embroider the beehive.

Thread Color #5 **Sterling (0142)** # _____

Embroider the shelf braces.

Thread Color #6 **Black (0020)** # _____

Embroider the outlining.

Drawn line extended 5" high 

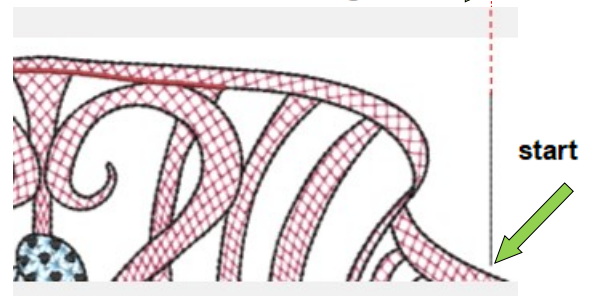

Example #7.

Remove the hoop from the module and the fabric from the hoop. 

Gently remove the stabilizer from the back because the **trail of stitches** following the bees **may pull out or loosen**.

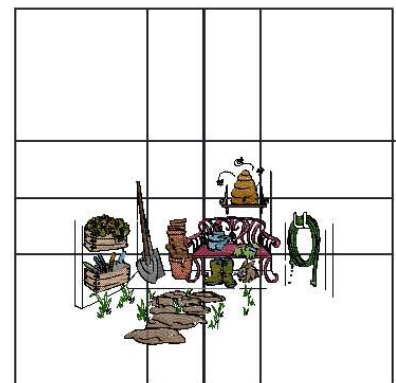

Copyright © 2019 Claudia Dinnell

All rights reserved. No part of this may be reproduced in any form or by any means without written permission from the copyright holder. These designs & instructions are for personal non-commercial use by the original purchaser only and are protected under US & International Laws.

Hooping #8 Seeds

Attach the hoop and the grid (no fabric) to the module.

Open #8 Seeds

Step #1 Advance to the **embroidery sewing screen** to go to the 1st stitch of the design.

Step #2 Lower the needle, lay an arrow shaped post it note on the grid with the tip of the arrow touching the needle. (The arrow is positioned about 4" above & 2 1/2" to the left of center)

Fabric Position:

To hoop this design the **Top of the Fabric** is **rotated** to the right of the hoop.

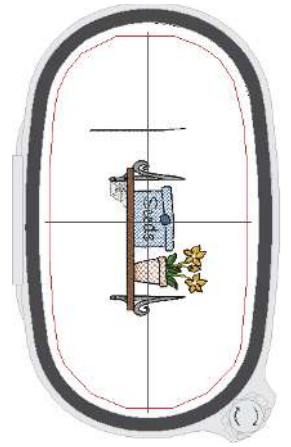
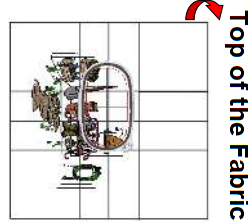

Hoop the fabric with the **arrow on the grid pointing to**

the green start arrow see **Example #8**. The drawn lines on the fabric must be parallel and perpendicular to the lines on the grid. Remove the grid from the hoop and attach the hoop to the module. **Float a piece of tear away stabilizer** (sprayed with 505) **under the attached hoop**.

No Thread Color #1 **Placement Line**.

The needle is positioned at the green start. See green arrow in **Example #8**.

Sew Color #1 without thread.

It sews from the start to the end arrow following the outline of the shovel.

Re-position if needed to follow the outline. Advance to **Color #2**.

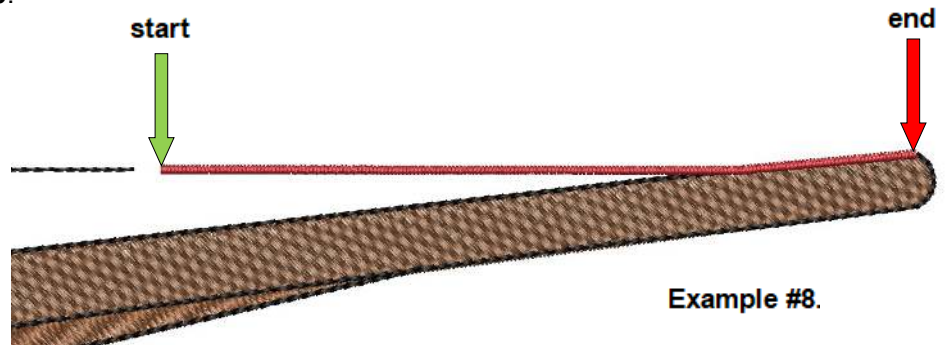

Thread Color #2 **Cornflower Blue (3713) # _____**

Embroider straight line & seed box. **Note: straight line** should be parallel to your drawn lines on the fabric.

Thread Color #3 **Green Grass (5722) # _____**

Embroider the leaves.

Thread Color #4 **Sterling (0142) # _____**

Embroider the spider web. An iridescent thread would be fun too!

Thread Color #5 **Light Cocoa (1134) # _____**

Embroider the shelf.

Thread Color #6 **Yellowgreen (6043) # _____**

Embroider the stems.

Thread Color #7 **Nutmeg (0932) # _____**

Embroider the pot.

Thread Color #8 **Melon (1430) # _____**

Embroider the flowers.

Thread Color #9 **White (0015) # _____**

Embroider the center of the flowers.

Thread Color #10 **Sterling (0142) # _____**

Embroider the shelf braces.

Thread Color #11 **Black (0020) # _____**

Embroider the outlining.

Remove the hoop from the module and the fabric from the hoop.

Gently remove the stabilizer from the back

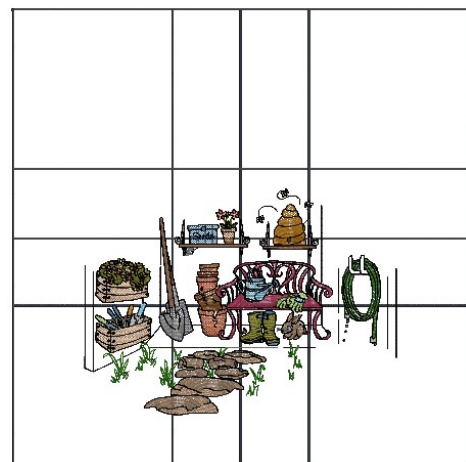

Copyright © 2019 Claudia Dinnell

All rights reserved. No part of this may be reproduced in any form or by any means without written permission from the copyright holder. These designs & instructions are for personal non-commercial use by the original purchaser only and are protected under US & International Laws.

Hooping #9 Tulips

Attach the hoop and the grid (no fabric) to the module. →



Open #9 Tulips

Step #1 Advance to the **embroidery sewing screen** to go to the 1st stitch of the design.

Step #2 Lower the needle, lay an arrow shaped post it note on the grid with the tip of the arrow touching the needle. (The arrow is positioned about 1 1/2" below & 3 1/2" to the right of center on the grid)

Fabric Position: To hoop this design the **Top of the Fabric** is positioned at the top of the hoop. →

Top of the Fabric

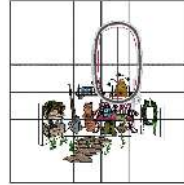

Hoop the fabric with the **arrow on the grid pointing to the green start arrow** see **Example #9**. The drawn lines on the fabric must be parallel and perpendicular to the lines on the grid. Remove the grid from the hoop and attach the hoop to the module.

Float two pieces of tear away stabilizer (sprayed with 505) **under the attached hoop**.

No Thread Color #1 **Needle Alignment**. The needle is positioned at the green start. See green arrow in **Example #9**.

Sew Color #1 without thread. It sews from the start arrow downward **3"** to the end arrow following **3"** of the stitched in black line. Re-position if needed to follow the line. Advance to **Color #2**.

Thread Color #2 **Light Cocoa (1134) # _____**
Embroider the shelf.

Thread Color #3 **Sterling (0142) # _____**
Embroider the shelf braces.

Thread Color #4 **Raspberry (2320) # _____**
Embroider the medium size flower pot.

Thread Color #5 **Apple Green (5730) # _____**
Embroider the greenery in center & bottom pots.

Thread Color #6 **Grape (2910) # _____**
Embroider the smaller flower pot.

Thread Color #7 **Heather Pink (2152) # _____**
Embroider the tulip.

Thread Color #8 **Grass Green (5722) # _____**
Embroider the leaves in the larger flower pot.

Thread Color #9 **Bright Yellow (0700) # _____**
Embroider the flowers and dragonfly wings.

Thread Color #10 **Chicory (3920) # _____**
Embroider the center flower pot & pattern on wings.

Thread Color #11 **Cardinal (1904) # _____**
Embroider the lady bug.

Thread Color #12 **Yellowgreen (6043) # _____**
Embroider the stems.

Thread Color #13 **Black (0020) # _____**
Embroider the outlining.

Remove the hoop from the module and the fabric from the hoop.

Gently remove the stabilizer from the back →

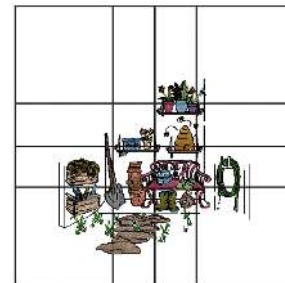
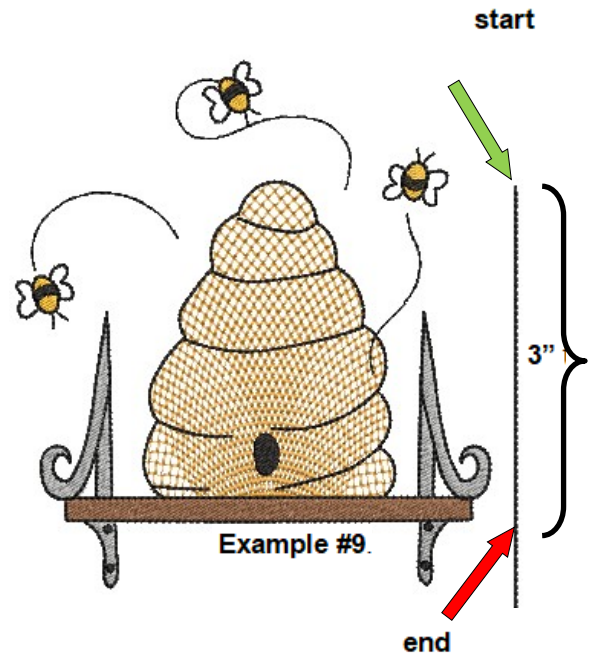

Copyright © 2019 Claudia Dinnell

All rights reserved. No part of this may be reproduced in any form or by any means without written permission from the copyright holder. These designs & instructions are for personal non-commercial use by the original purchaser only and are protected under US & International Laws.

Hooping #10 Potting Shed Sign

Attach the hoop and the grid (no fabric) to the module.

Open #10 Sign

Step #1 Advance to the **embroidery sewing screen** to go to the 1st stitch of the design.

Step #2 Lower the needle, lay an arrow shaped post it note on the grid with the tip of the arrow touching the needle. (The arrow is positioned about 5" below and 1½ to the left of center on the grid)

Fabric Position: To hoop this design the **Top of the Fabric** is positioned at the top of the hoop.

Hoop the fabric with the **arrow on the grid pointing to the green start arrow** see **Example #10**. Remove the grid and attach the hoop to the module. **Float two pieces of tear away stabilizer** (sprayed with 505) **under the attached hoop**.

No Thread Color #1 Placement Line.

The needle is positioned at the green start. See green arrow in **Example #10**. Sew Color #1 without thread, it sews from the start to the end arrow following the outline of the shelf. Advance to **2nd Start**: The needle is position at the **2nd Start arrow** above the shovel. Re-position if needed to align the needle at the second mark touching the shovel.

Advance to **Color #2**.

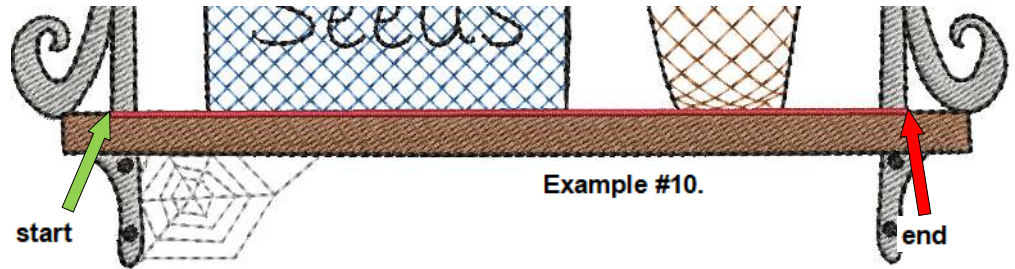

Thread Color #2 **Light Cocoa (1134) #** _____
Embroider the shelf.

Thread Color #3 **Sterling (0142) #** _____
Embroider the shelf braces.

Thread Color #4 **Green Grass (5722) #** _____
Embroider the greenery.

Thread Color #5 **Wild Iris (2830) #** _____
Embroider the flower pot.

Thread Color #6 **Bright Yellow (0700) #** _____
Embroider the flower centers.

Thread Color #7 **Cardinal (1904) #** _____
Embroider the flowers.

Thread Color #8 **Liberty Gold (0824) #** _____
Embroider the sign.

Thread Color #9 **White (0015) #** _____
Embroider the white squares on the border of the sign.

Thread Color #10 **Steel (2674) #** _____
Embroider the spade.

Thread Color #11 **Black (0020) #** _____
Embroider the checkerboard and the outlining.

Thread Color #12 **Steel (2674) #** _____
Embroider the spider.

Remove the hoop from the module and the fabric from the hoop.

Gently remove the stabilizer from the back

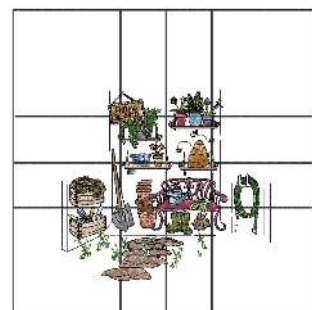
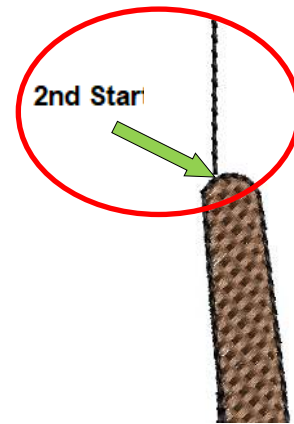

Copyright © 2019 Claudia Dinnell

All rights reserved. No part of this may be reproduced in any form or by any means without written permission from the copyright holder. These designs & instructions are for personal non-commercial use by the original purchaser only and are protected under US & International Laws.

Hooping #1 Left Lower Shutter

Select **#2 Shutters & Roof** folder.
Attach the hoop and the grid (no fabric) to the module.

Open #1 Left Lower Shutter

Step #1 Advance to the **embroidery sewing screen** to go to the 1st stitch of the design.

Step #2 Lower the needle, lay an arrow shaped post it note on the grid with the tip of the arrow touching the needle. (The arrow is positioned about 3" above and to the left of center on the grid)

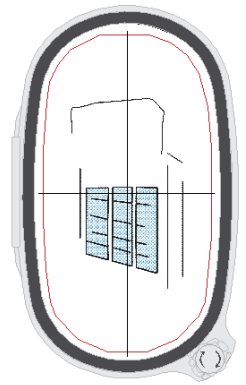

Fabric Position: upside down

To hoop this design the **Top of the Fabric** is positioned at the **BOTTOM** of the hoop.

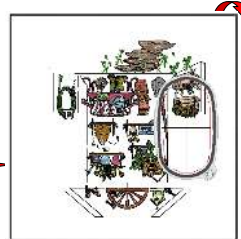

Top of the Fabric

Hoop the fabric with the **arrow on the grid pointing to the green start arrow** see **Example #1**. The drawn lines on the fabric must be parallel and perpendicular to the lines on the grid. Remove the grid from the hoop and attach the hoop to the module.

Float one piece of tear away stabilizer (sprayed with 505) **under the attached hoop**.

Example #1.

Thread Color #1 Placement Line.

The needle is positioned at the green start.

See green arrow in **Example #1**.

Sew Color #1 without thread.

It sews from the start arrow (upward & around the flower box) to the end arrow following the outline of the flower box (path shown in red): then moves to touch both ends of the lines representing the wall. The wall lines must align. If needed, move the design **left or right** (not up & down) to align the needle directly on the ends of the stitched in lines.

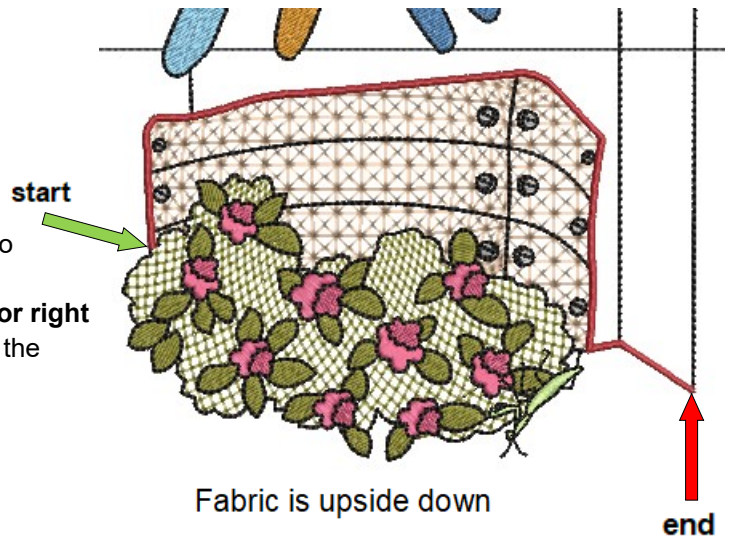

Fabric is upside down

Advance to **Color #2**.

Thread Color #2 **Chicory (3920) # _____**

Embroider the windows.

Thread Color #3 **Black (0020) # _____**

Embroider the outlining.

Remove the hoop from the module and the fabric from the hoop.

Gently remove the stabilizer from the back.

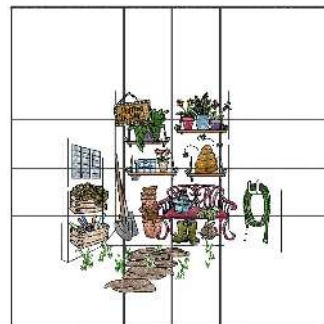

Copyright © 2019 Claudia Dinnell

All rights reserved. No part of this may be reproduced in any form or by any means without written permission from the copyright holder. These designs & instructions are for personal non-commercial use by the original purchaser only and are protected under US & International Laws.

Hooping #2 Left Upper Shutter

Attach the hoop and the grid (no fabric) to the module.

Open #2 Left Upper Shutter

Step #1 Advance to the **embroidery sewing screen** to go to the 1st stitch of the design.

Step #2 Lower the needle, lay an arrow shaped post it note on the grid with the tip of the arrow touching the needle. (The arrow is positioned about 5 1/2" above and 2 1/2" to the left of center on the grid)

Fabric Position: upside down

To hoop this design the **Top of the Fabric** is positioned at the **BOTTOM** of the hoop.

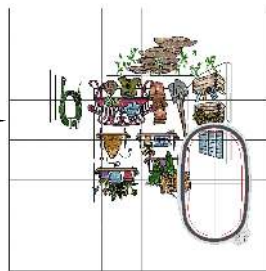

Top of the Fabric

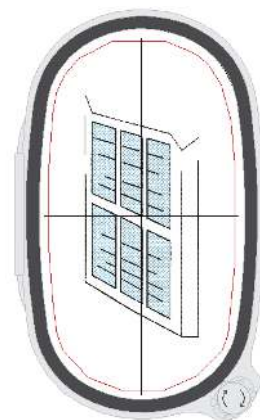

Hoop the fabric with the **arrow on the grid pointing to the green start arrow** see **Example #2**. The drawn lines on the fabric must be parallel and perpendicular to the lines on the grid. Remove the grid from the hoop and attach the hoop to the module.

Float one piece of tear away stabilizer (sprayed with 505) **under the attached hoop**.

Thread Color #1 **Needle Alignment**. The needle is positioned at the green start. See green arrow in **Example #2**. Sew Color #1 without thread

It sews from the start (end of line on the left) to the end arrow downward and across to the right following the outline of the window: then up to touch both ends of the lines representing the wall.

Re-position if needed to follow the line.

Advance to **Color #2**.

Thread Color #2 **Chicory (3920) # _____**
Embroider the windows.

Thread Color #3 **Black (0020) # _____**
Embroider the outlining.

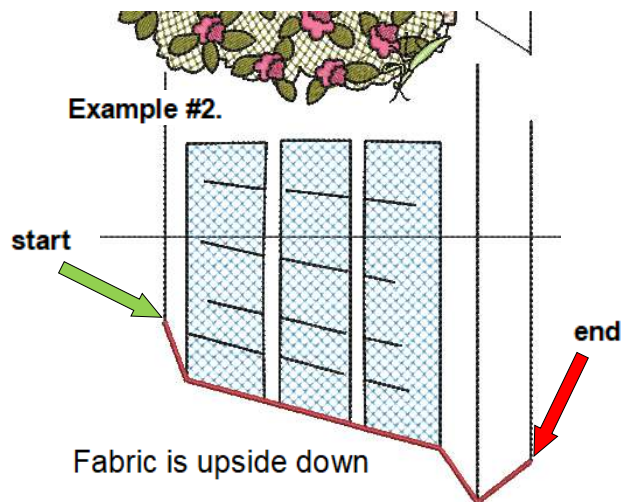

Fabric is upside down

Remove the hoop from the module and the fabric from the hoop.

Gently remove the stabilizer from the back

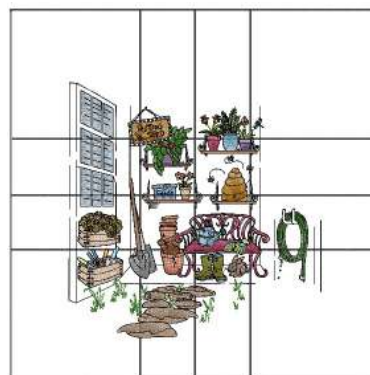

Copyright © 2019 Claudia Dinnell

All rights reserved. No part of this may be reproduced in any form or by any means without written permission from the copyright holder. These designs & instructions are for personal non-commercial use by the original purchaser only and are protected under US & International Laws.

New Marking required for remaining Hoopings.

With a removable pen, extend the lines located on both sides of the hose, about **10" high**. This will help you hoop the fabric straight with the already embroidered design. The fabric can easily get out of "square" and this will help you hoop straight.

These new marks are your **new Vertical Straight Lines**. They may or may not be parallel with the previously drawn vertical lines. Use these new lines to hoop the fabric for the remaining designs.

Use a square ruler to align the horizontal and vertical position before you start to draw the line.

Ruler alignment shown in RED below.

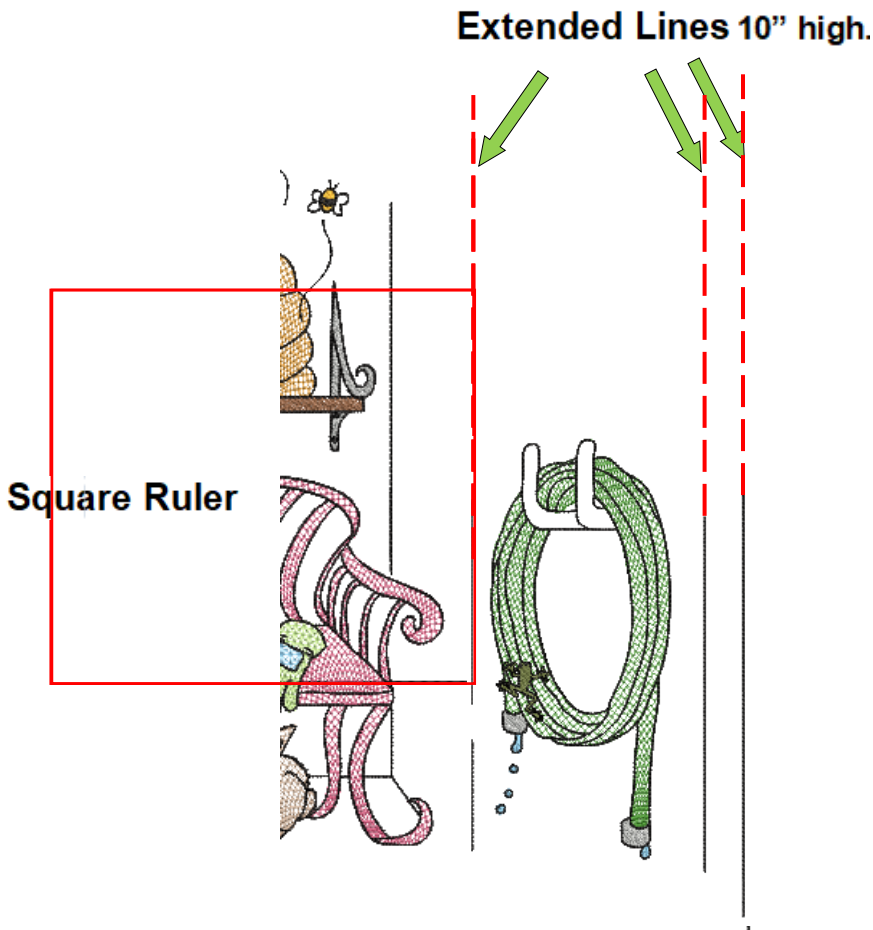
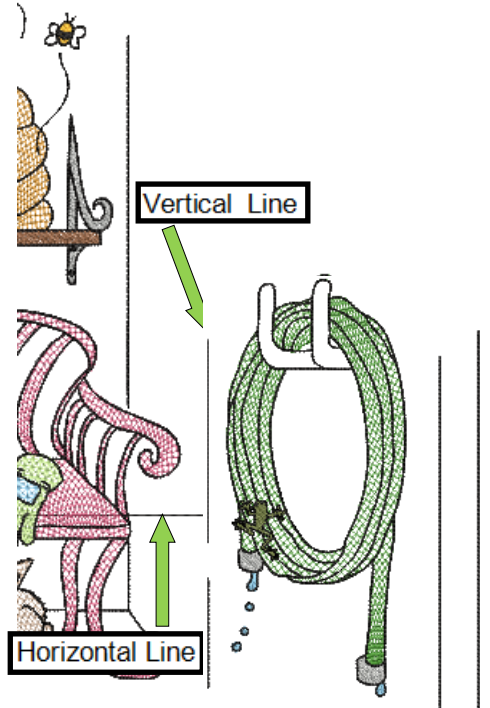

Hooping #3 Right Lower Shutter

Attach the hoop and the grid (no fabric) to the module.

Open #3 Right Lower Shutter

Step #1 Advance to the **embroidery sewing screen** to go to the 1st stitch of the design.

Step #2 Lower the needle, lay an arrow shaped post it note on the grid with the tip of the arrow touching the needle. (The arrow is positioned about 5 ½ below and 2 ½" to the left of center on the grid)

Fabric Position:

To hoop this design the **Top of the Fabric** is positioned at the top of the hoop.

Top of the Fabric

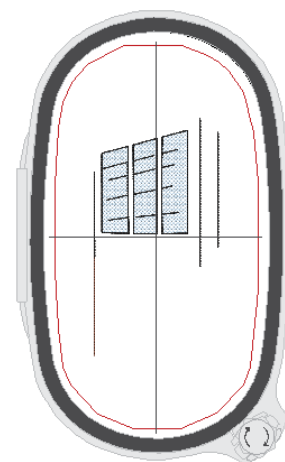
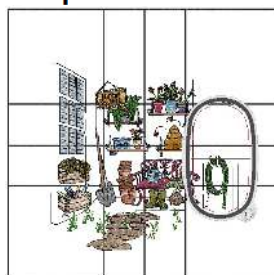

Hoop the fabric with the **arrow on the grid pointing to the green start arrow** see **Example #3**. The drawn lines on the fabric must be parallel and perpendicular to the lines on the grid. Remove the grid from the hoop and attach the hoop to the module. **Float one piece of tear away stabilizer under the attached hoop** (sprayed with 505).

Thread Color #1 Placement Line.

The needle is positioned at the green start.

See green arrow in **Example #3**.

Sew Color #1 without thread. It sews from the start arrow up 7 ¾" to the end arrow following the stitched in line. Then it moves to the top of outside **stitched in wall line** to the right side of the hose (see red circle).

You may need to re-position to get all 3 points correct.

Advance to **Color #2**.

Thread Color #2 **Chicory (3920) # _____**

Embroider the windows.

Thread Color #3 **Black (0020) # _____**

Embroider the outlining.

Remove the hoop from the module and the fabric from the hoop. Gently remove the stabilizer from the back.

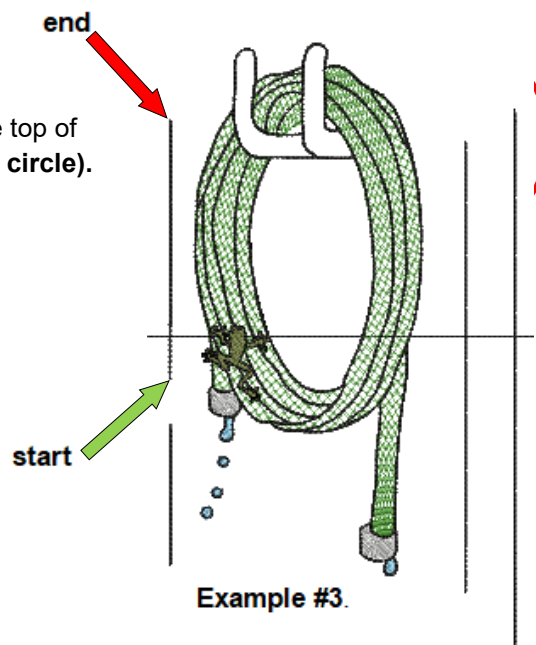
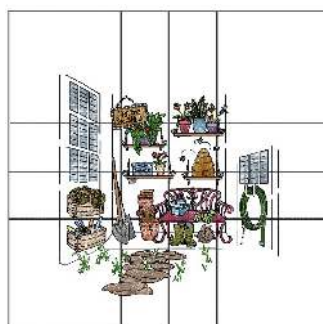

Example #3.

Copyright © 2019 Claudia Dinnell

All rights reserved. No part of this may be reproduced in any form or by any means without written permission from the copyright holder. These designs & instructions are for personal non-commercial use by the original purchaser only and are protected under US & International Laws.

www.claudiascreationsaz.com

Hooping #4 Right Upper Shutter

Attach the hoop and the grid (no fabric) to the module.

Open #4 Right Upper Shutter

Step #1 Advance to the **embroidery sewing screen** to go to the 1st stitch of the design.

Step #2 Lower the needle, lay an arrow shaped post it note on the grid with the tip of the arrow touching the needle. (The arrow is positioned about 4" below and 3" to the right of center on the grid)

Fabric Position:

To hoop this design the **Top of the Fabric** is positioned at the top of the hoop.



Top of the Fabric

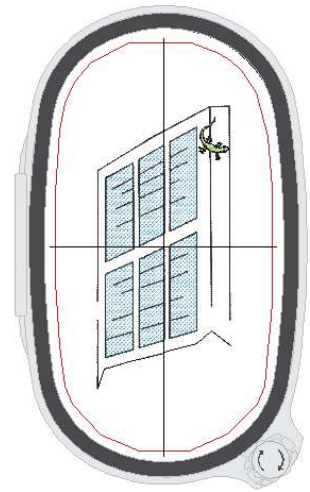
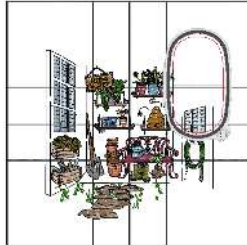

Hoop the fabric with the **arrow on the grid pointing to the green start arrow** see **Example #4**. The drawn lines on the fabric must be parallel and perpendicular to the lines on the grid. Remove the grid from the hoop and attach the hoop to the module. **Float one piece of tear away stabilizer** (sprayed with 505) **under the attached hoop**.

Thread Color #1 Placement Line.

The needle is positioned at the green start. See green arrow in

Example #4. Sew Color #1 without thread

It sews from the start to the end arrow following the outline of the window and then up the newly drawn line.

Be sure to nail each of the angles the best you can!

Re-position if needed to follow the outline.

Advance to **Color #2**.

Thread Color #2 **Chicory (3920) # _____**

Embroider the windows.

Thread Color #3 **Black (0020) # _____**

Embroider the outlining of the shutters.

Thread Color #4 **Apple Green (5730) # _____**

Embroider the lizard.

Thread Color #5 **Black (0020) # _____**

Embroider the outlining of the lizard.

Remove the hoop from the module and the fabric from the hoop. Gently remove the stabilizer from the back.

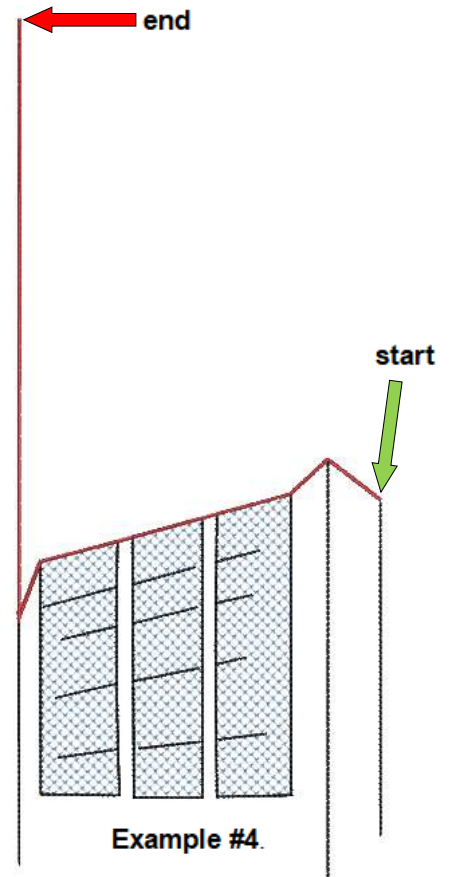

Example #4.

Copyright © 2019 Claudia Dinnell

All rights reserved. No part of this may be reproduced in any form or by any means without written permission from the copyright holder. These designs & instructions are for personal non-commercial use by the original purchaser only and are protected under US & International Laws.

Prep for Hooping #5 #6 #7

Mark the Fabric:

Turn the fabric with the top of the fabric on the right.

Lay the **20 1/2" square ruler** on the fabric (shown below as **red square**).

Align the **top edge** of the ruler at the **inside edge of the door tops** (see green arrows).

Now, look at the sewn in line representing the **floor** on the Potting Shed (**line in front of the boots**).

The ruler should be **parallel** to the ceiling line and the floor line before you draw the ceiling line.

Draw the ceiling line.

If it is not, balance out the lines the best you can!

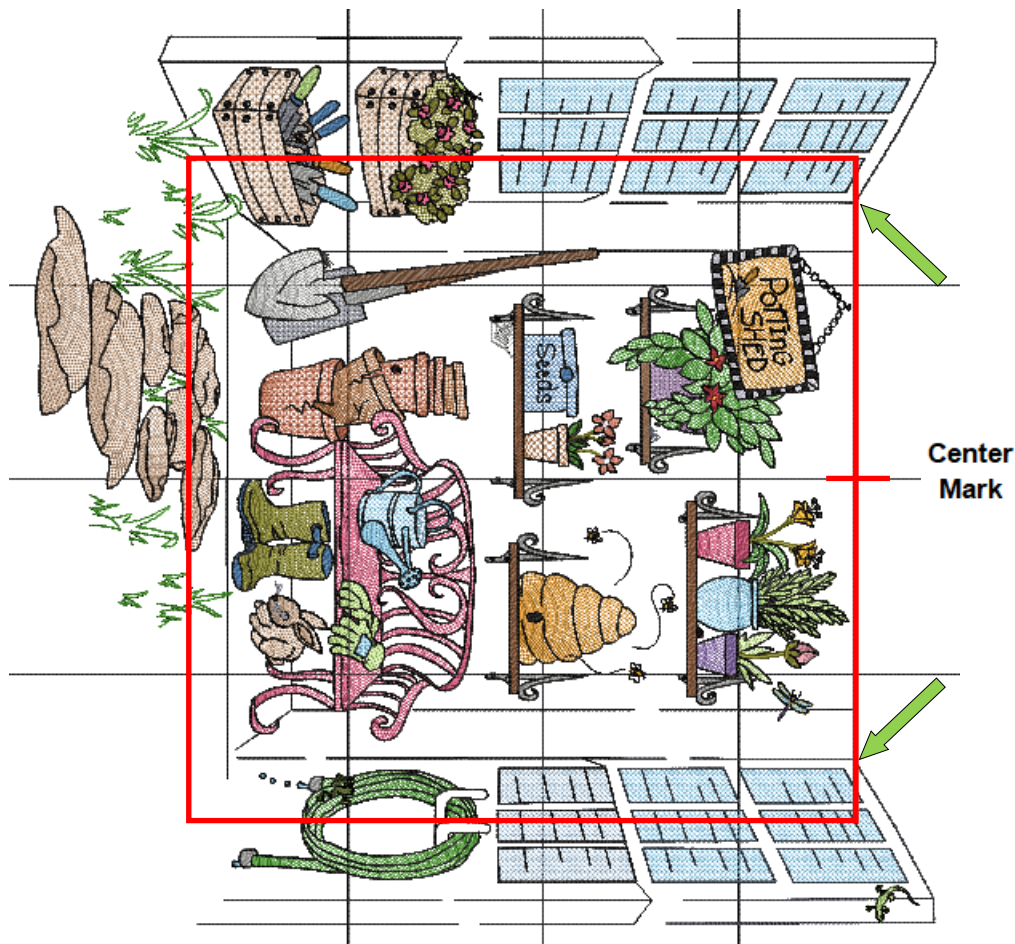

Draw a center mark on the ceiling line between the two doors.

Measure your embroidery to find the center between the two doors.

Continue to Hooping #5.

Copyright © 2019 Claudia Dinnell

All rights reserved. No part of this may be reproduced in any form or by any means without written permission from the copyright holder. These designs & instructions are for personal non-commercial use by the original purchaser only and are protected under US & International Laws.

Hooping #5 Birdhouse

Attach the hoop and the grid (no fabric) to the module.

Open #5 Birdhouse

Step #1 Advance to the **embroidery sewing screen** to go to the 1st stitch of the design.

Step #2 Lower the needle, lay an arrow shaped post it note on the grid with the tip of the arrow touching the needle. (The arrow is positioned 1 1/2" above and 3" to the left of center on the grid)

Fabric Position:

To hoop this design the **Top of the Fabric** is rotated to the right of the hoop.

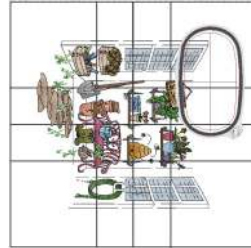

Top of the Fabric

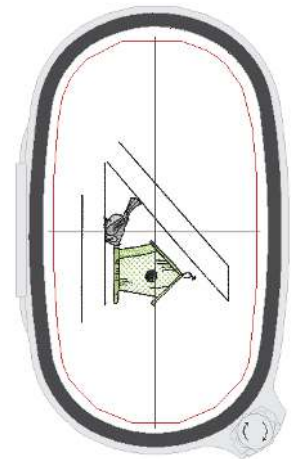

Hoop the fabric with the **arrow on the grid pointing to the green start arrow**.

See green and red arrows in **Example #5**.

Remove the grid from the hoop and attach the hoop to the module.

Float a piece of tear away stabilizer (sprayed with 505) **under the attached hoop**.

Thread Color #1 Placement Line.

The needle is positioned at the green start see **Example #5**.

Sew Color #1 without thread. It sews from the start arrow down 5"

following the line you just drew. Re-position if needed to follow the outline.

Advance to **Color #2**.

Thread Color #2 Apple Green (5730) # _____

Embroider the birdhouse.

Thread Color #3 Sterling (0142) # _____

Embroider the upper part of the bird.

Thread Color #4 White (0015) # _____

Embroider the under body of the bird.

Thread Color #5 Liberty Gold (0824) # _____

Embroider the beak.

Thread Color #6 Black (0020) # _____

Embroider the outlining.

Remove the hoop from the module and the fabric from the hoop. Gently remove the stabilizer from the back.



Example #5.

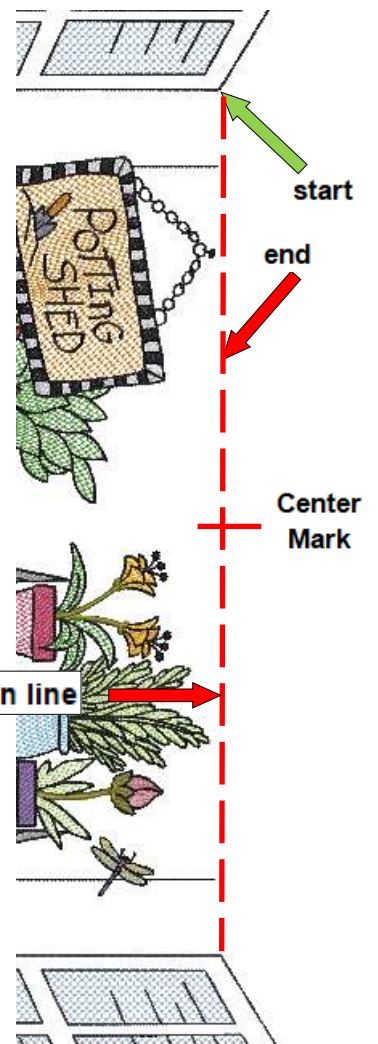

Newly drawn line

Copyright © 2019 Claudia Dinnell

All rights reserved. No part of this may be reproduced in any form or by any means without written permission from the copyright holder. These designs & instructions are for personal non-commercial use by the original purchaser only and are protected under US & International Laws.

Hooping #6 Sparrows

Attach the hoop and the grid (no fabric) to the module.

Note: Larger Hoops select **Combo Folder**, this will add #7 Center to this hooping.
After #6 Sparrows follow page #24 for #7 Center thread colors.

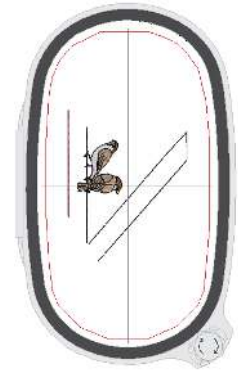
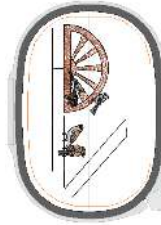

Open #6 Sparrows

Step #1 Advance to the **embroidery sewing screen** to go to the 1st stitch of the design.
Step #2 Lower the needle, lay an arrow shaped post it note on the grid with the tip of the arrow touching the needle. (The arrow is positioned about 1 1/2" below and 3" to the left of center on the grid)

Fabric Position:

To hoop this design the **Top of the Fabric** is rotated to the right of the hoop.

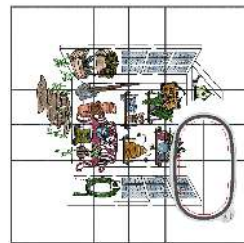

Top of the Fabric

Hoop the fabric with the **arrow on the grid pointing to the green start arrow** see **Example #6**. Remove the grid from the hoop and attach the hoop to the module.
Float a piece of tear away stabilizer (sprayed with 505) **under the attached hoop**.

Thread Color #1 Placement Line.

The needle is positioned at the green start see **Example #6**.
Sew Color #1 without thread.
It sews from the green start arrow upward 5" to the end arrow following the newly drawn line.
Re-position if needed to follow the outline.
Advance to **Color #2**.

Thread Color #2 **Redwood (0933)** # _____

Embroider the top of the birds heads.

Thread Color #3 **Steel (2674)** # _____

Embroider the area around the beak.

Thread Color #4 **White (0015)** # _____

Embroider the lower bodies on the birds.

Thread Color #5 **Carmel Cream (1123)** # _____

Embroider the upper bodies on the birds.

Thread Color #6 **Liberty Gold (0824)** # _____

Embroider the beak.

Thread Color #7 **Black (0020)** # _____

Embroider the outlining.

Remove the hoop from the module and the fabric from the hoop.

Gently remove the stabilizer from the back.

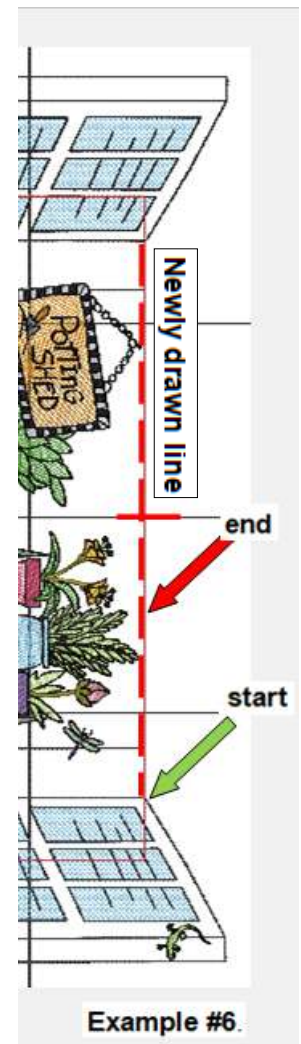
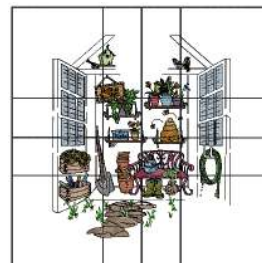

Example #6.

Copyright © 2019 Claudia Dinnell

All rights reserved. No part of this may be reproduced in any form or by any means without written permission from the copyright holder. These designs & instructions are for personal non-commercial use by the original purchaser only and are protected under US & International Laws.

www.claudiascreationsaz.com

Hooping #7 Center Roof

Attach the hoop and the grid (no fabric) to the module.

Open #7 Center Roof

Step #1 Advance to the **embroidery sewing screen** to go to the 1st stitch of the design.

Step #2 Lower the needle, lay an arrow shaped post it note on the grid with the tip of the arrow touching the needle. (The arrow is positioned about 3 1/2" above and 2 1/2' to the left of center on the grid)

Fabric Position:

To hoop this design the **Top of the Fabric** is Rotated to the **RIGHT** of the hoop.

Please Read:

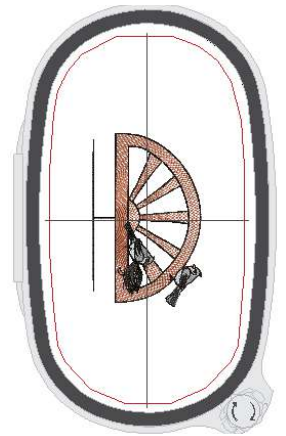
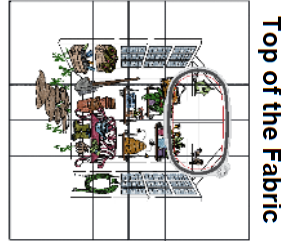

Hoop the fabric with the **arrow on the grid pointing to the green start arrow** see **Example #7**. The drawn lines on the fabric must be parallel and perpendicular to the lines on the grid. Remove the grid from the hoop and attach the hoop to the module. **Float one piece of tear away stabilizer** (sprayed with 505) **under the attached hoop**.

Thread Color #1 Placement Line.

The needle is positioned at the green start. See **Example #7**.

Sew Color #1 without thread. It starts at the lower end of the embroidered roof line next to the green bird house and sews downward to the top end top end of the embroidered roof line next to the Sparrows, following the newly drawn line.

2nd Start:

Advance through Color #1 to the **2nd Start**. The needle must line up with the **Center Mark**. Use the move motif icon if needed to re-position the design up or down (only) to align with the **Center Mark**. Advance to **Color #2**.

Thread Color #2 **Date (1311) #** _____

Embroider the architectural roof feature.

Thread Color #3 **Sterling (0142) #** _____

Embroider the upper bodies of the birds.

Thread Color #4 **Redwood (0933) #** _____

Embroider the nest.

Thread Color #5 **White (0015) #** _____

Embroider the lower bodies of the birds.

Thread Color #6 **Liberty Gold (0824) #** _____

Embroider the beak.

Thread Color #7 **Black (0020) #** _____

Embroider the outlining.

Remove the hoop from the module and the fabric from the hoop. Gently remove the stabilizer from the back.

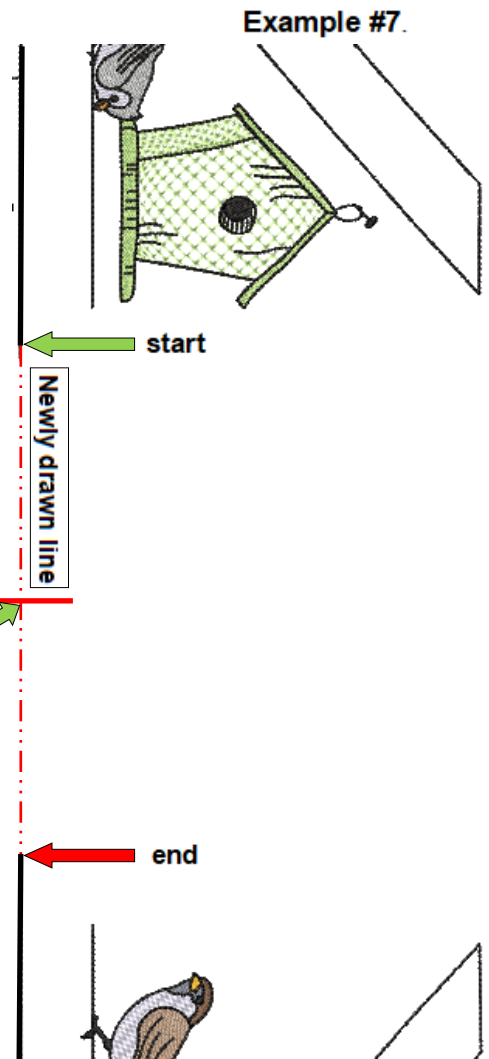
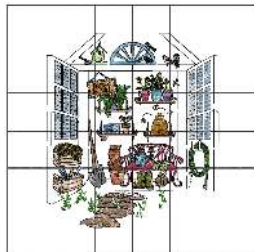

Copyright © 2019 Claudia Dinnell

All rights reserved. No part of this may be reproduced in any form or by any means without written permission from the copyright holder. These designs & instructions are for personal non-commercial use by the original purchaser only and are protected under US & International Laws.

Instructions for Embroidered Center Top

- Remove the excess stabilizer from the back of the block.
- Remove all the markings on the front of the block. I pin my block to my design wall and spray with water. Let dry.
- Press and starch the embroidered block (I use a wool mat to press the fabric) You may have “embroidery wrinkles” which will not be seen after the quilting. Press the fabric as carefully as possible not to distort the shape.

Marking the Top:

Centering the design on the block, draw a $30\frac{1}{2}$ " square around the design. To do this:

I placed a $20\frac{1}{2}$ " square ruler and a $12\frac{1}{2}$ " square ruler next to each other and positioned them on the fabric with the top edge of the ruler aligned with the top of the embroidery and the left edge of the ruler centered on the design.

I could then draw the top and left side. Then flip the fabric and draw the other two lines.

Note: Remember together the rulers measure 33" we only want to use $30\frac{1}{2}$ " of the width.

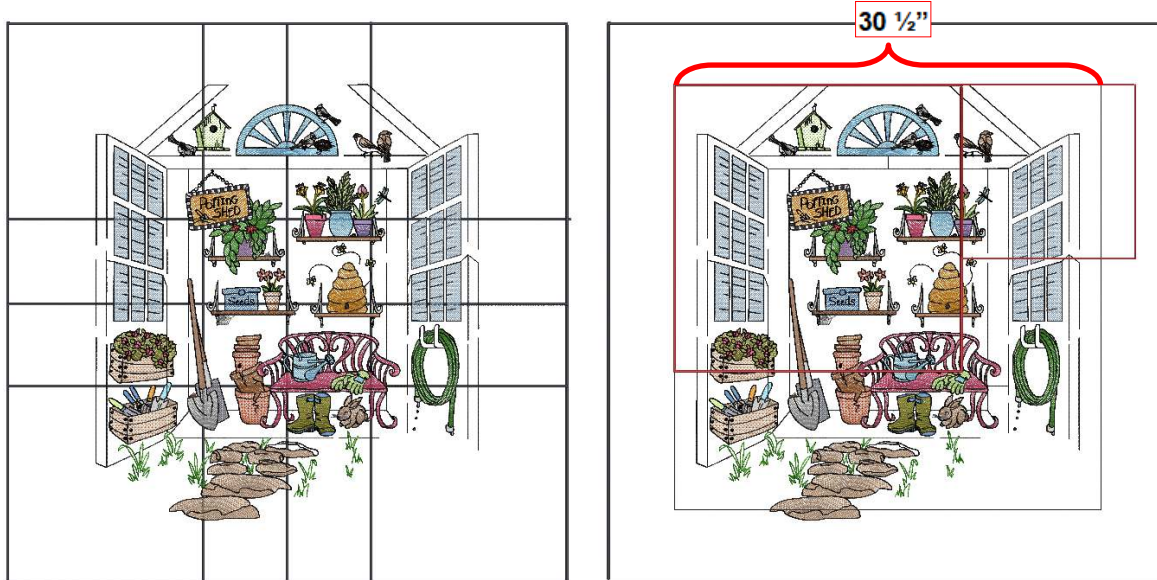

I had $1\frac{1}{2}$ " on either side of the embroidery. Use your measurement it may be wider or narrower than mine.

Draw the side lines. Use the square rulers to mark the corners this will ensure a 90° corner.

Draw the bottom line $30\frac{1}{2}$ " below the top line. It will cut through the stone.

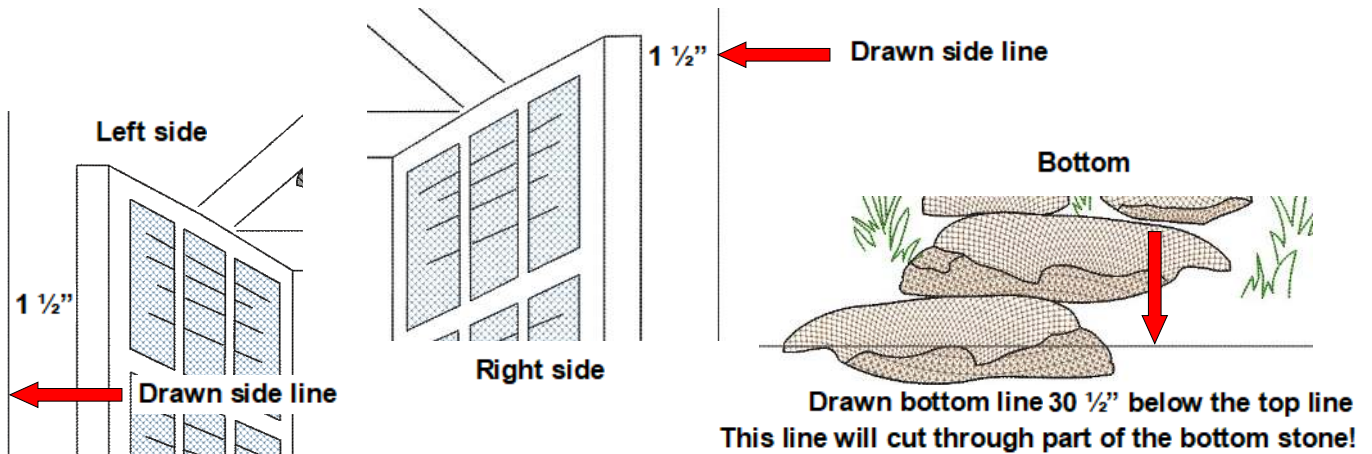

If you have any questions: please go to my **YouTube Channel** and watch a video on it!!

Claudiascreationsaz / The Potting Shed / Trimming the Center Top

Copyright © 2019 Claudia Dinnell

All rights reserved. No part of this may be reproduced in any form or by any means without written permission from the copyright holder. These designs & instructions are for personal non-commercial use by the original purchaser only and are protected under US & International Laws.

Add Borders to the Center Top

Optional: Add Perfect **Quarter Inch Borders** to the Center before adding the Inner Borders.

YouTube / claudiascreationsaz / **Perfect Quarter Inch Borders**

Border Fabric: (1 ¾ yards)

Cut (1) 8" & (1) 16" strip x length of fabric 68"

Interfacing:

Shape Flex 101 by Pellon or Fusible Woven by OESD

Cut (1) 8" strip by 68"

Cut (1) 16" strip by 68"

Center and Iron interfacing to the back of the fabric strips.

If needed, piece the interfacing to get the length.

Over lap the pieced sections by ½".

The interfacing may shrink & be smaller than the fabric strip when you iron it. Lightly spray with water to activate the adhesive. Smooth the interfacing with your hands (this will help to displace the air between the interfacing & fabric).

Start pressing in the center and work out slowly. Iron the interfacing to the fabric. All edges should be sealed together.

If you see air bubbles, spray with water and iron again. Watch my Fabric Prep video for a demo.

2.5" x 68"	
2.5" x 68"	Inner Borders
2.5" x 68"	Inner Borders
3.5" x 68"	
3.5" x 68"	Outer Borders
3.5" x 68"	
3.5" x 68"	

Starch the fabric strip. (Faultless Heavy Spray Starch)

Sub Cut the 8" strip of Inner Border Fabric:

Cut **(3) 2 ½"** width x the Length of Fabric (68") strips

Cut **(1)** strip in half =

(2) 2 ½" width x the Length of Fabric (68") strips

(2) 2 ½" width x 34" strips

Measure the width (30 ½") of the **Center Section**.

Sub cut the shorter strips to your width measurement

(2) 30 ½" strips

Pin & sew your strips to the top & bottom.

Press the seams to the inner border.

Quilt measures 30 ½" x 34 ½" (width x height)

(or your measurement)

Sub Cut **(2) remaining** strips 2 ½" x 34 (or your measurement)

Sew these strips to the left and right sides.

Quilt measures 34 ½" x 34 ½" (or your measurement)

Wait to cut the outer borders until

all the embroidery is completed.

Set the **Center Bordered Top** aside.

Continue with the **Embroidered Borders**.

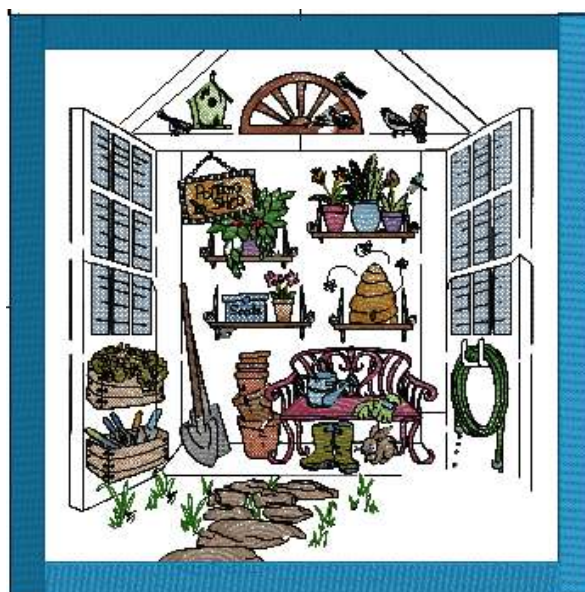

Copyright © 2019 Claudia Dinnell

All rights reserved. No part of this may be reproduced in any form or by any means without written permission from the copyright holder. These designs & instructions are for personal non-commercial use by the original purchaser only and are protected under US & International Laws.

Embroidered Borders

Background Fabric:

The remaining background fabric is cut

Lengthwise in half (not widthwise)

Cut (2) borders: 22" x 64" Wide x Length

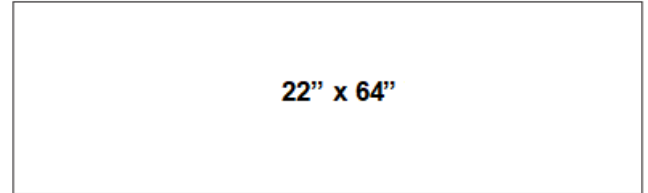
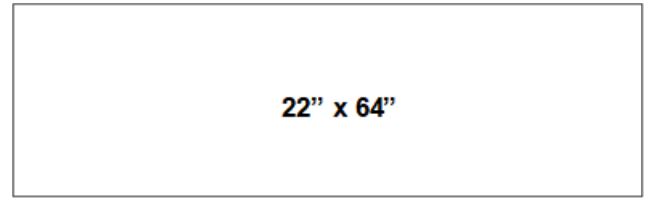

Fabric Preparation

Terrial Magic.

Saturate the background fabric (shown above) in **Terrial Magic**.

This product is a heavy starch. The fabric must be very stiff to avoid stretching during embroidery.

Let the fabric almost dry then iron the fabric flat and smooth.

Interfacing: Shape Flex 101 by Pellon or Fusible Woven by OESD

Follow the **Fabric Preparation instructions** on **page #5** for applying Interfacing.

Mark the Fabric:

Draw (2) **64"** straight lines down the length of the fabric **6"** to the inside from **both** outer edges.

Draw (1) 22" straight line across the center **width** of fabric.

The two long lines & the center line must be **parallel and perpendicular** to each other.

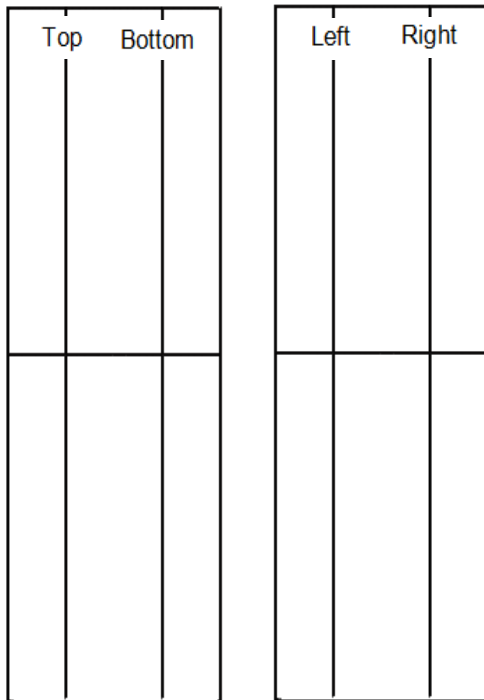
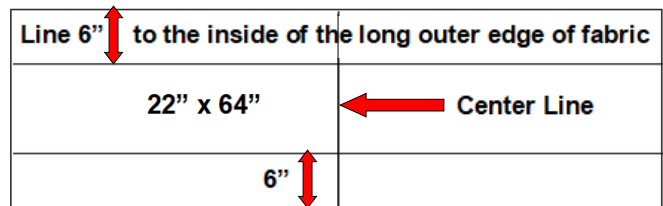
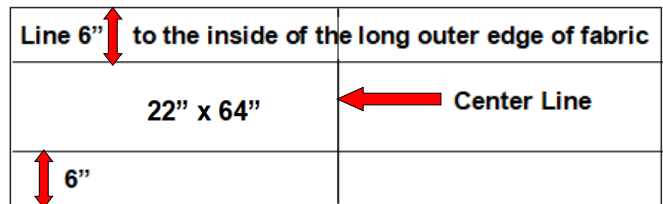

Write the name of each border at the **top** of the fabric strip.

← See **Example**.

Set aside the **Left/Right** borders.

Start with the Top Border.

Copyright © 2019 Claudia Dinnell

All rights reserved. No part of this may be reproduced in any form or by any means without written permission from the copyright holder. These designs & instructions are for personal non-commercial use by the original purchaser only and are protected under US & International Laws.

Embroidered Borders

1 Top Border

Attach the hoop and the grid (no fabric) to the module.

Open the **1 Top Border** Folder

Open #1 AboveCenter

Step #1 Advance to the **embroidery sewing screen** to go to the 1st stitch of the design.

Step #2 Lower the needle, lay an arrow shaped post it note on the grid with the tip of the arrow touching the needle. (The arrow is positioned about 3 1/2" below center on the grid)

Fabric Position:

To hoop this design the **Top of the Fabric** is positioned at the top of the hoop.

Hoop the fabric with the **arrow on the grid pointing to the center crosshair**.

See green start arrow in **Example #1**.

Remove the grid from the hoop and attach the hoop to the module.

Float a piece of tear away stabilizer (sprayed with 505) **under the attached hoop**.

Thread Color #1 Needle Alignment.

The needle is positioned over the center crosshair on the fabric.

See **Example #1**. Do not sew Color #1 it is a needle alignment only

Re-position if needed to align the needle.

Advance to **Color #2**.

Thread Color #2 **Wild Iris (2830) #** _____

Embroider the top of the flowers.

Thread Color #3 **Bright Yellow (0700) #** _____

Embroider the bees and flower centers.

Thread Color #4 **Grape (2910) #** _____

Embroider the base of the flowers.

Thread Color #5 **Green Grass (5722) #** _____

Embroider the leaves.

Thread Color #6 **Chicory (3920) #** _____

Embroider the hummingbird body.

Thread Color #7 **Grasshopper (5933) #** _____

Embroider the inside of the stem.

Thread Color #8 **Cornflower (3713) #** _____

Embroider the bird wings.

Thread Color #9 **Yellowgreen (6043) #** _____

Embroider the stems.

Thread Color #10 **Liberty Gold (0824) #** _____

Embroider the beak.

Thread Color #11 **Apple Green (5730) #** _____

Embroider the chest of the bird.

Thread Color #12 **Black (0020) #** _____

Embroider the outline and future placement line!

Be careful not to rip out when removing the stabilizer.

Remove the hoop from the module and the fabric from the hoop.

Gently remove the stabilizer from the back.



Top of the Fabric

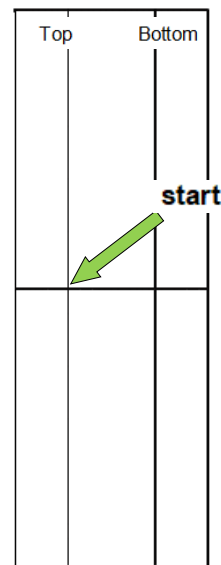
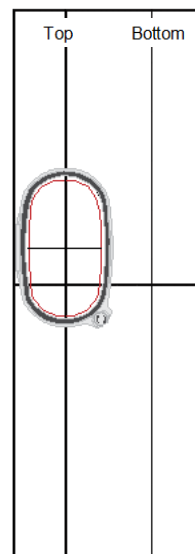

Example #1.

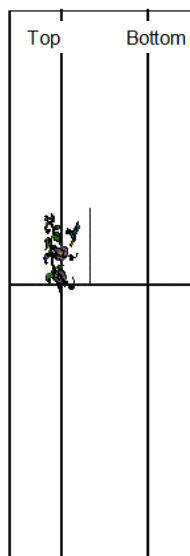

Copyright © 2019 Claudia Dinnell

All rights reserved. No part of this may be reproduced in any form or by any means without written permission from the copyright holder. These designs & instructions are for personal non-commercial use by the original purchaser only and are protected under US & International Laws.

Top Border

Attach the hoop and the grid (no fabric) to the module.

Open #2 Below Center (I'm using the words above and below because the border is stitching vertically)

Step #1 Advance to the **embroidery sewing screen** to go to the 1st stitch of the design.

Step #2 Lower the needle, lay an arrow shaped post it note on the grid with the tip of the arrow touching the needle. (The arrow is positioned about 5" above and 1" to the left of center on the grid)

Fabric Position:

To hoop this design the **Top of the Fabric** is positioned at the top of the hoop.

Hoop the fabric with the **arrow on the grid pointing to the center crosshair**. See green start arrow in **Example #2**. Placement is below the Center hooping. Remove the grid from the hoop and attach the hoop to the module.

Float a piece of tear away stabilizer (sprayed with 505) **under the attached hoop**.

Thread Color #1 Needle Alignment.

The needle is positioned at the green start arrow.

See **Example #2**. Sew Color #1 without thread. It sews from the start downward to the end arrow following the outline of the stem.

Re-position if needed to align the needle.

Advance to **Color #2**.

Thread Color #2 **Wild Iris (2830) # _____**

Embroider the top of the flowers.

Thread Color #3 **Cornflower Blue (3713) # _____**

Embroider the hummingbird body.

Thread Color #4 **Grape (2910) # _____**

Embroider the base of the flowers & dragonfly wings.

Thread Color #5 **Green Grass (5722) # _____**

Embroider the leaves.

Thread Color #6 **Bright Yellow (0700) # _____**

Embroider the flower centers.

Thread Color #7 **Yellowgreen (6043) # _____**

Embroider the stems.

Thread Color #8 **Chicory (3920) # _____**

Embroidery the dragonfly and bird wings.

Thread Color #9 **Apple Green (5730) # _____**

Embroider the dragonfly body and bird chest.

Thread Color #10 **Liberty Gold (0824) # _____**

Embroider the beak.

Thread Color #11 **Black (0020) # _____**

Embroider the outline and future placement line!

Thread Color #12 **Apple Green (5730) # _____**

Embroider the lizard body.

Thread Color #13 **Black (0020) # _____**

Embroider the outline and future placement line.

Remove the hoop from the module and the fabric from the hoop.

Gently remove the stabilizer from the back.

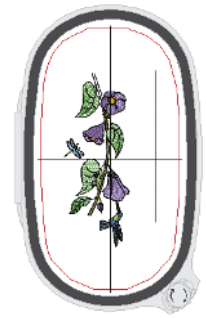

Top of the Fabric

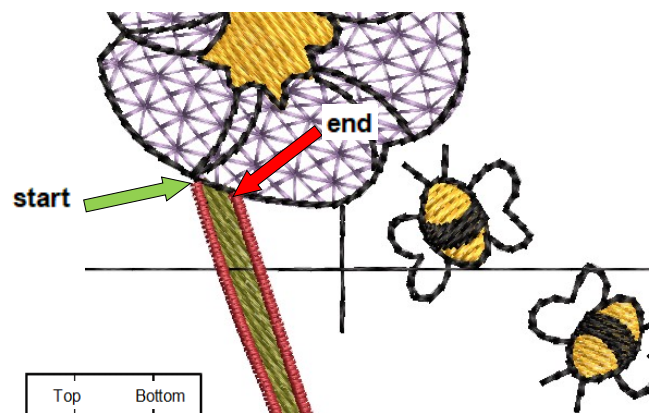
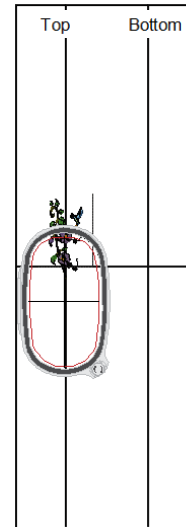

Example #2.

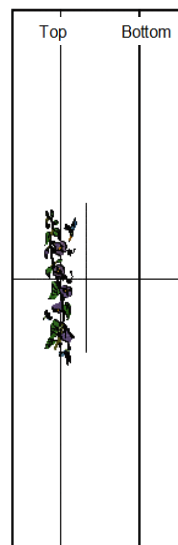

Copyright © 2019 Claudia Dinnell

All rights reserved. No part of this may be reproduced in any form or by any means without written permission from the copyright holder. These designs & instructions are for personal non-commercial use by the original purchaser only and are protected under US & International Laws.

Top Border

Attach the hoop and the grid (no fabric) to the module.

Open #3 Below Hooping 2

Step #1 Advance to the **embroidery sewing screen** to go to the 1st stitch of the design.

Step #2 Lower the needle, lay an arrow shaped post it note on the grid with the tip of the arrow touching the needle.

(The arrow is positioned about 5" above and 1" to the left of center on the grid)

Fabric Position:

To hoop this design the **Top of the Fabric** is positioned at the top of the hoop.

Hoop the fabric with the **arrow on the grid pointing to the green start arrow**. See green start arrow in **Example #3**. Placement is below the Center Hooping. Remove the grid from the hoop and attach the hoop to the module.

Float a piece of tear away stabilizer (sprayed with 505) **under the attached hoop**.

Thread Color #1 Placement Line.

The needle is positioned at the green start arrow.

See **Example #3**. Sew Color #1 without thread. It sews from the start downward to the end arrow following the outline of the stem. Re-position if needed to the outline. Advance to **Color #2**.

Thread Color #2 **Wild Iris (2830) #** _____

Embroider the top of the flowers.

Thread Color #3 **Green Grass (5722) #** _____

Embroider the leaves.

Thread Color #4 **Grape (2910) #** _____

Embroider the base of the flowers.

Thread Color #5 **Yellowgreen (6043) #** _____

Embroider the stems.

Thread Color #6 **Bright Yellow (0700) #** _____

Embroider the flower centers & bees.

Thread Color #7 **Apple Green (5730) #** _____

Embroider the bird chest.

Thread Color #8 **Cornflower Blue (3713) #** _____

Embroider the hummingbird body.

Thread Color #9 **Liberty Gold (0824) #** _____

Embroider the beak.

Thread Color #10 **Chicory (3920) #** _____

Embroidery the bird wings.

Thread Color #11 **Black (0020) #** _____

Embroider the outline and future placement line!

Remove the hoop from the module and the fabric from the hoop.

Gently remove the stabilizer from the back.

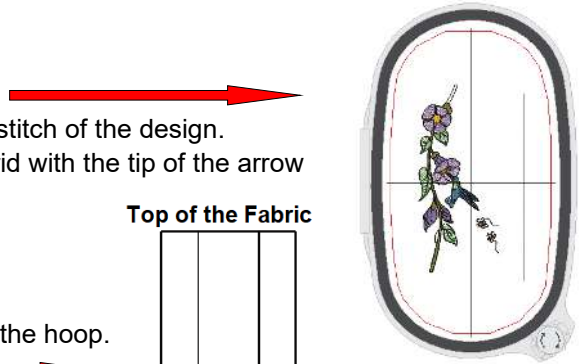

Top of the Fabric

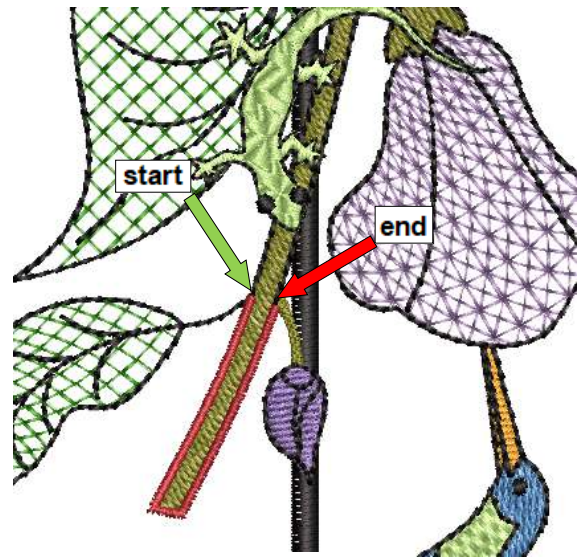
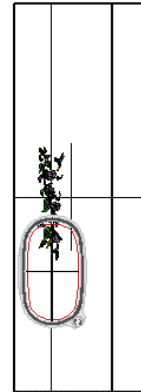

Example #3.



Copyright © 2019 Claudia Dinnell

All rights reserved. No part of this may be reproduced in any form or by any means without written permission from the copyright holder. These designs & instructions are for personal non-commercial use by the original purchaser only and are protected under US & International Laws.

2 Bottom Border

Attach the hoop and the grid (no fabric) to the module.

Open 2 Bottom Folder

Open #1 Center

Step #1 Advance to the **embroidery sewing screen** to go to the 1st stitch of the design.

Step #2 Lower the needle, lay an arrow shaped post it note on the grid with the tip of the arrow touching the needle.

(The arrow is positioned about 1 1/2" above and 1/2" to the right of center on the grid)

Fabric Position:

To hoop this design the **Top of the Fabric** is positioned at the top of the hoop.

Hoop the fabric with the **arrow on the grid pointing to the center crosshair on the fabric**. See green start arrow in **Example #1**.

Remove the grid from the hoop and attach the hoop to the module.

Float a piece of tear away stabilizer (sprayed with 505) **under the attached hoop**.

Thread Color #1 Needle Alignment.

The needle is positioned over the center crosshair on the fabric.

See **Example #1**. Do not sew Color #1 it is a needle alignment only

Re-position if needed to align the needle.

Advance to **Color #2**

Thread Color #2 **Wild Iris (2830) #** _____

Embroider the top of the flowers.

Thread Color #3 **Grasshopper (5933) #** _____

Embroider the underside of stems.

Thread Color #4 **Grape (2910) #** _____

Embroider the base of the flowers.

Thread Color #5 **Yellowgreen (6043) #** _____

Embroider the stems.

Thread Color #6 **Bright Yellow (0700) #** _____

Embroider the flower centers and bees.

Thread Color #7 **Green Grass (5722) #** _____

Embroider the leaves.

Thread Color #8 **Black (0020) #** _____

Embroider the outline and future placement line!

Remove the hoop from the module and the fabric from the hoop.

Gently remove the stabilizer from the back.

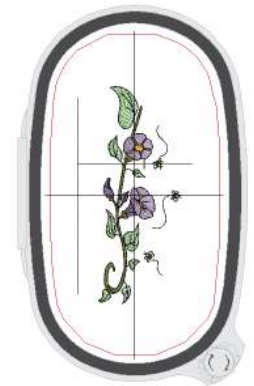

Top of the Fabric

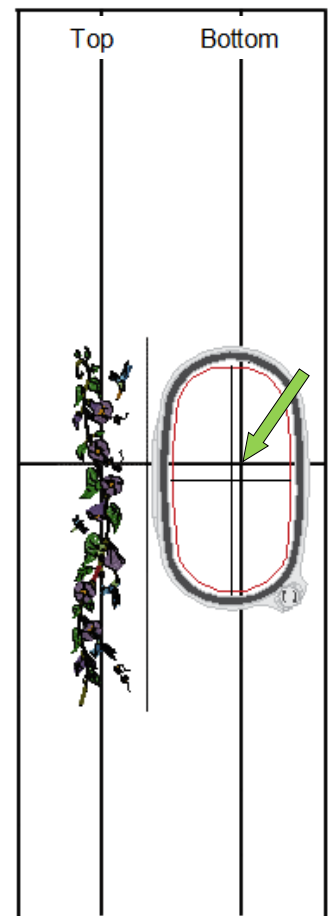
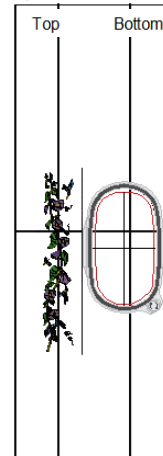

Example #1.



Copyright © 2019 Claudia Dinnell

All rights reserved. No part of this may be reproduced in any form or by any means without written permission from the copyright holder. These designs & instructions are for personal non-commercial use by the original purchaser only and are protected under US & International Laws.

Bottom Border

Attach the hoop and the grid (no fabric) to the module.

Open #2 Above Center

Step #1 Advance to the **embroidery sewing screen** to go to the 1st stitch of the design.

Step #2 Lower the needle, lay an arrow shaped post it note on the grid with the tip of the arrow touching the needle. (The arrow is positioned about 3 1/2" below and 1/2" to the left of center on the grid)

Fabric Position:

To hoop this design the **Top of the Fabric** is positioned at the top of the hoop.

Hoop the fabric with the **arrow on the grid pointing to the green start arrow**. See green start arrow in **Example #2**. Placement is above the Center hooping. Remove the grid from the hoop and attach the hoop to the module.

Float a piece of tear away stabilizer (sprayed with 505) **under the attached hoop**.

Thread Color #1 Placement Line.

The needle is positioned at the top left end of the stem.

See green start arrow in **Example #2**. Sew Color #1 without thread.

It sews from the start arrow down the stem and back up to the end arrow following the outline of the stem.

Re-position if needed to follow the outline.

Advance to **Color #2**

Thread Color #2 **Grape (2910) #** _____

Embroider the base of the flowers.

Thread Color #3 **Green Grass (5722) #** _____

Embroider the leaves.

Thread Color #4 **Wild Iris (2830) #** _____

Embroider the top of the flowers.

Thread Color #5 **Yellowgreen (6043) #** _____

Embroider the stems.

Thread Color #6 **Bright Yellow (0700) #** _____

Embroider the flower centers, butterfly and dragonfly wings.

Thread Color #7 **Chicory (3920) #** _____

Embroidery the body of the bird and dragonfly wings.

Thread Color #8 **Apple Green (5730) #** _____

Embroider the bird chest and dragonfly body.

Thread Color #9 **Liberty Gold (0824) #** _____

Embroider the beak & butterfly.

Thread Color #10 **Cornflower Blue (3713) #** _____

Embroider the hummingbird wings.

Thread Color #11 **Black (0020) #** _____

Embroider the outline and future placement line!

Remove the hoop from the module and the fabric from the hoop.

Gently remove the stabilizer from the back.

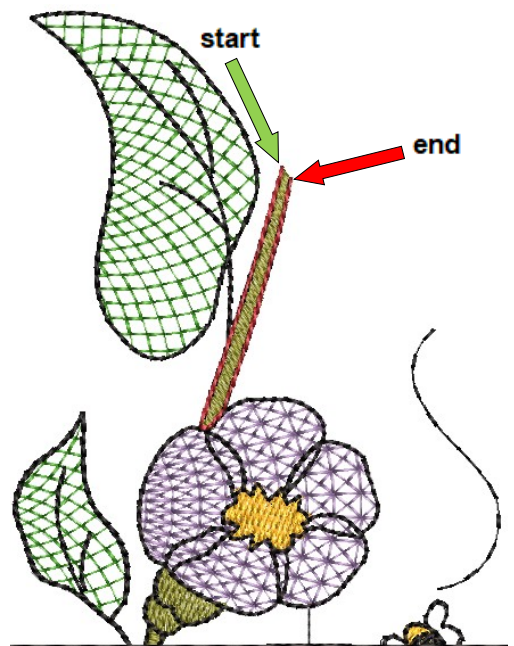
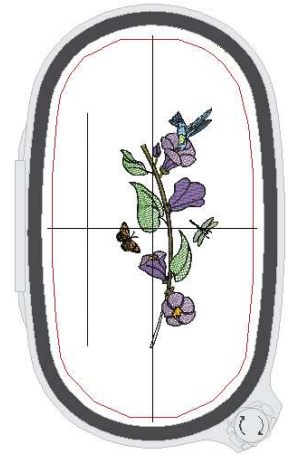

Example #2.



Copyright © 2019 Claudia Dinnell

All rights reserved. No part of this may be reproduced in any form or by any means without written permission from the copyright holder. These designs & instructions are for personal non-commercial use by the original purchaser only and are protected under US & International Laws.

Bottom Border

Attach the hoop and the grid (no fabric) to the module.

Open #3 Below Center (Quail)

Step #1 Advance to the **embroidery sewing screen** to go to the 1st stitch of the design.

Step #2 Lower the needle, lay an arrow shaped post it note on the grid with the tip of the arrow touching the needle.

(The arrow is positioned about 5 1/2" above and 1/2" to the left of center on the grid)

Fabric Position:

To hoop this design the **Top of the Fabric** is positioned at the top of the hoop. Same as the last hooping.

Hoop the fabric with the **arrow on the grid pointing to the green start arrow**.

See green start arrow in **Example #3**. Placement is below the Center hooping.

Remove the grid from the hoop and attach the hoop to the module.

Float a piece of tear away stabilizer (sprayed with 505) **under the attached hoop**.

Thread Color #1 Placement Line.

The needle is positioned at the green start arrow at the end of the black outline just above the leaf. It sews to the end arrow following the "C" shape of the stem.

See **Example #3**. Re-position if needed to follow the outline.

Advance to **Color #2**

Thread Color #2 **Green Grass (5722) #** _____

Embroider the leaves.

Thread Color #3 **Redwood (0933) #** _____

Embroider the legs.

Thread Color #4 **Sterling (0142) #** _____

Embroider the mama's body and spider web.

Thread Color #5 **Yellowgreen (6043) #** _____

Embroider the stems.

Thread Color #6 **Penny (1154) #** _____

Embroider the baby quails.

Thread Color #7 **Steel (2674) #** _____

Embroidery the mama's head.

Thread Color #8 **White (0015) #** _____

Embroider the bird's chests.

Thread Color #9 **Liberty Gold (0824) #** _____

Embroider the beaks.

Thread Color #10 **Grasshopper (5933) #** _____

Embroider the stems linings.

Thread Color #11 **Bright Yellow (700) #** _____

Embroider the bees.

Thread Color #12 **Black (0020) #** _____

Embroider the outline and future placement line!

Remove the hoop from the module and the fabric from the hoop.

Gently remove the stabilizer from the back.

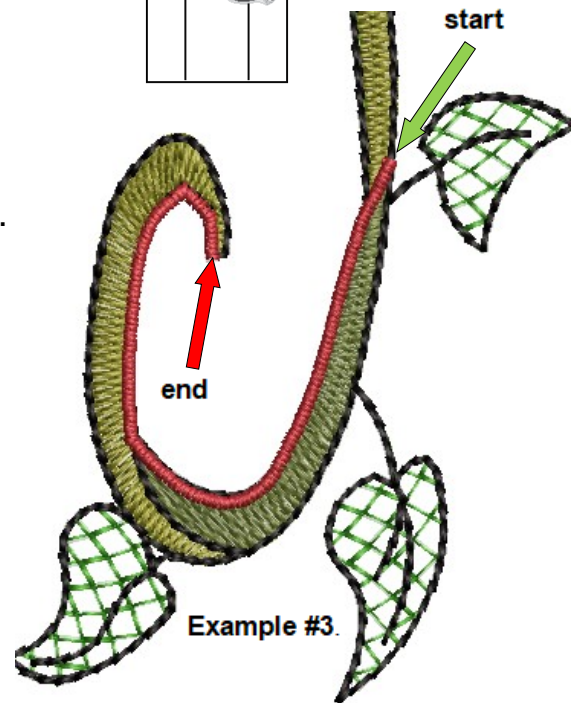
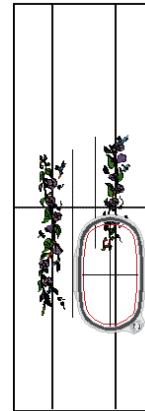
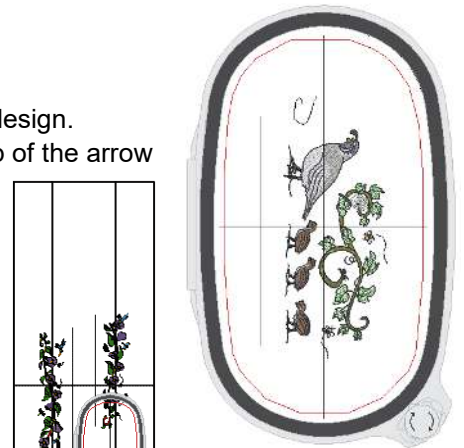

Copyright © 2019 Claudia Dinnell

All rights reserved. No part of this may be reproduced in any form or by any means without written permission from the copyright holder. These designs & instructions are for personal non-commercial use by the original purchaser only and are protected under US & International Laws.

3 Left Border

Attach the hoop and the grid (no fabric) to the module.

Open 3 Left Border Folder

Open #1 Center

Step #1 Advance to the **embroidery sewing screen** to go to the 1st stitch of the design.

Step #2 Lower the needle, lay an arrow shaped post it note on the grid with the tip of the arrow touching the needle.

(The arrow is positioned about 4 ½" below and slightly to the right of center on the grid)

Fabric Position:

To hoop this design the **Top of the Fabric** is positioned at the top of the hoop.

Hoop the fabric with the **arrow on the grid pointing to the center crosshair on the fabric**. See green start arrow in **Example #1**.

Remove the grid from the hoop and attach the hoop to the module.

Float a piece of tear away stabilizer (sprayed with 505) **under the attached hoop**.

Thread Color #1 Needle Alignment.

The needle is positioned over the center crosshair on the fabric.

See **Example #1**. Do not sew Color #1 it is a needle alignment only

Re-position if needed to align the needle.

Advance to **Color #2**

Thread Color #2 **Green Grass (5722) # _____**

Embroider the leaves.

Thread Color #3 **Liberty Gold (0824) # _____**

Embroider the beak.

Thread Color #4 **Yellowgreen (6043) # _____**

Embroider the stems.

Thread Color #5 **Raspberry (2320) # _____**

Embroider the butterfly wings.

Thread Color #6 **Grasshopper (5933) # _____**

Embroider the under side of the stems and frog.

Thread Color #7 **Bright Yellow (0700) # _____**

Embroider the dragonfly wings.

Thread Color #8 **Apple Green (5730) # _____**

Embroider the dragonfly body.

Thread Color #9 **Cornflower Blue (3713) # _____**

Embroider the butterfly wing and dragonfly wings.

Thread Color #10 **White (0015) # _____**

Embroidery the chest of the bird.

Thread Color #11 **Sterling (0142) # _____**

Embroider the bird body.

Thread Color #12 **Black (0020) # _____**

Embroider the outline and future placement line!

Remove the hoop from the module and the fabric from the hoop.

Gently remove the stabilizer from the back.

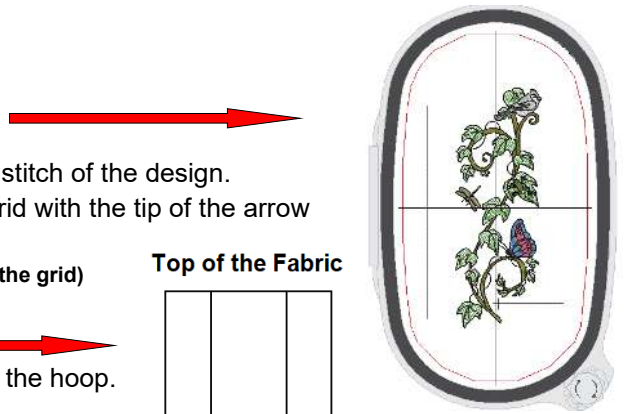

Top of the Fabric

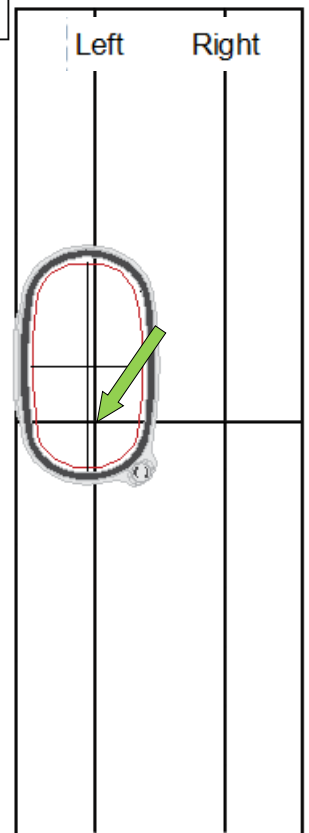
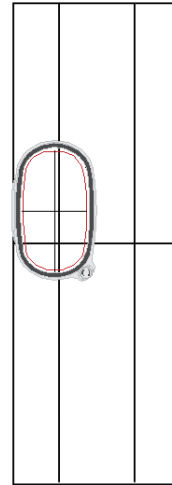

Example #1.

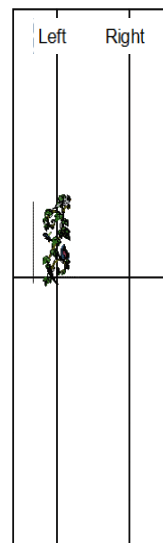

Copyright © 2019 Claudia Dinnell

All rights reserved. No part of this may be reproduced in any form or by any means without written permission from the copyright holder. These designs & instructions are for personal non-commercial use by the original purchaser only and are protected under US & International Laws.

3 Left Border

Attach the hoop and the grid (no fabric) to the module.

Open #2 Below Center

Step #1 Advance to the **embroidery sewing screen** to go to the 1st stitch of the design.

Step #2 Lower the needle, lay an arrow shaped post it note on the grid with the tip of the arrow touching the needle.

(The arrow is positioned about 5 1/2" above and slightly to the left of center on the grid)

Fabric Position:

To hoop this design the **Top of the Fabric** is positioned at the top of the hoop.

Hoop the fabric with the **arrow on the grid pointing to the green start arrow**.

See green start arrow in **Example #2**. Placement below previous hooping.

Remove the grid from the hoop and attach the hoop to the module.

Float a piece of tear away stabilizer (sprayed with 505) **under the attached hoop**.

Thread Color #1 Placement Line:

The needle is positioned at the green start arrow.

See **Example #2**. Sew Color #1 without thread. It sews from the start arrow (bottom of the stem) to the end arrow following the outline of the stem.

Re-position if needed to follow the stem outline.

Advance to **Color #2**

Thread Color #2 **Green Grass (5722) # _____**

Embroider the leaves.

Thread Color #3 **Raspberry (2320) # _____**

Embroider the butterfly wings.

Thread Color #4 **Yellowgreen (6043) # _____**

Embroider the stems.

Thread Color #5 **White (0015) # _____**

Embroidery the bird body.

Thread Color #6 **Grasshopper (5933) # _____**

Embroider the under side of the stems and lizard.

Thread Color #7 **Bright Yellow (0700) # _____**

Embroider the bees, butterfly wings and beak.

Thread Color #8 **Steel (2674) # _____**

Embroider the bird wings and head.

Thread Color #9 **Apple Green (5730) # _____**

Embroider the butterfly wings.

Thread Color #10 **Liberty Gold (0824) # _____**

Embroider the butterfly wings.

Thread Color #11 **Redwood (0933) # _____**

Embroider the top of the bird head.

Thread Color #12 **Black (0020) # _____**

Embroider the outline and future placement line!

Remove the hoop from the module and the fabric from the hoop.

Gently remove the stabilizer from the back.

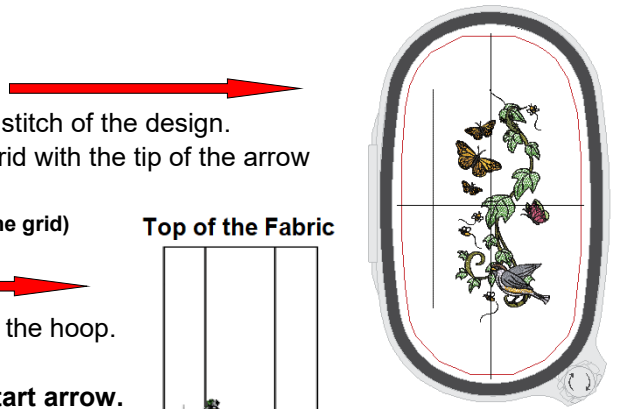

Top of the Fabric

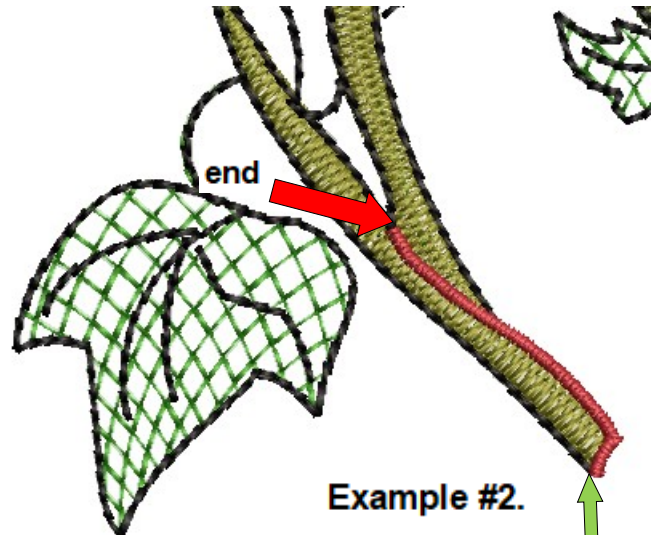
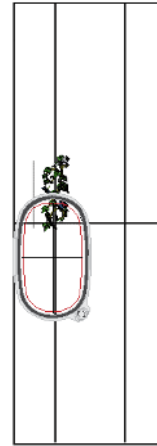

Example #2.

start

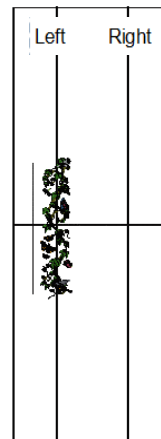

Copyright © 2019 Claudia Dinnell

All rights reserved. No part of this may be reproduced in any form or by any means without written permission from the copyright holder. These designs & instructions are for personal non-commercial use by the original purchaser only and are protected under US & International Laws.

Left Border

Attach the hoop and the grid (no fabric) to the module.

Open #3 Above Center

Step #1 Advance to the **embroidery sewing screen** to go to the 1st stitch of the design.

Step #2 Lower the needle, lay an arrow shaped post it note on the grid with the tip of the arrow touching the needle.

(The arrow is positioned about 4" below and 1 1/2" to the right of center on the grid)

Fabric Position:

To hoop this design the **Top of the Fabric** is positioned at the top of the hoop.

Hoop the fabric with the **arrow on the grid pointing to the green start arrow**.

See green start arrow in **Example #3**. Placement above Center hooping.

Remove the grid from the hoop and attach the hoop to the module.

Float a piece of tear away stabilizer (sprayed with 505) **under the attached hoop**.

Thread Color #1 Placement Line:

The needle is positioned at the green start arrow.

See **Example #3**. Sew Color #1 without thread. It sews

from the start arrow (right side of leaf) to the end arrow following the outline of the leaf.

Re-position if needed to follow the leaf outline.

Advance to **Color #2**

Thread Color #2 **Green Grass (5722) #** _____

Embroider the leaves.

Thread Color #3 **Bright Yellow (0700) #** _____

Embroider the butterfly wings.

Thread Color #4 **Yellowgreen (6043) #** _____

Embroider the stems.

Thread Color #5 **Chicory (3920) #** _____

Embroidery the butterfly wings.

Thread Color #6 **Raspberry (2320) #** _____

Embroider the butterfly wings.

Thread Color #7 **White (0015) #** _____

Embroider the bird's chest.

Thread Color #8 **Sterling (0142) #** _____

Embroider the bird's body.

Thread Color #9 **Liberty Gold (0824) #** _____

Embroider the butterfly wings and beak.

Thread Color #10 **Black (0020) #** _____

Embroider the outline and future placement line!

Remove the hoop from the module and the fabric from the hoop.

Gently remove the stabilizer from the back.

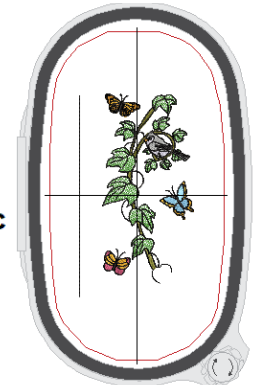

Top of the Fabric

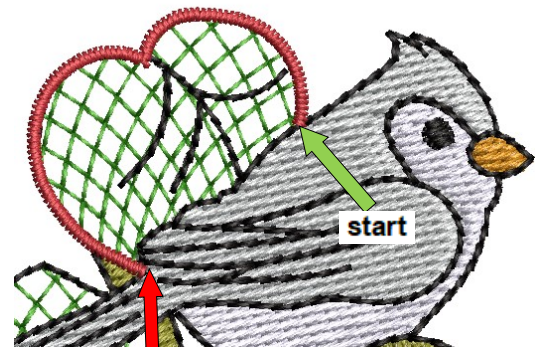

Example #3.

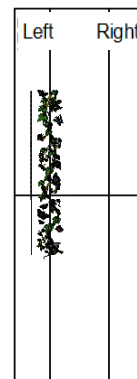

Copyright © 2019 Claudia Dinnell

All rights reserved. No part of this may be reproduced in any form or by any means without written permission from the copyright holder. These designs & instructions are for personal non-commercial use by the original purchaser only and are protected under US & International Laws.

4 Right Border

Attach the hoop and the grid (no fabric) to the module.

Open 4 Right Border Folder

Open #1 Center

Step #1 Advance to the **embroidery sewing screen** to go to the 1st stitch of the design.

Step #2 Lower the needle, lay an arrow shaped post it note on the grid with the tip of the arrow touching the needle.

(The arrow is positioned about 1" below and slightly to the right of center on the grid)

Fabric Position:

To hoop this design the **Top of the Fabric** is positioned at the top of the hoop.

Hoop the fabric with the **arrow on the grid pointing to the center crosshair on the fabric**. See green start arrow in **Example #1**.

Remove the grid from the hoop and attach the hoop to the module.

Float a piece of tear away stabilizer (sprayed with 505) **under the attached hoop**.

Thread Color #1 Needle Alignment.

The needle is positioned over the center crosshair on the fabric.

See **Example #1**. Do not sew Color #1 it is a needle alignment only

Re-position if needed to align the needle.

Advance to **Color #2**

Thread Color #2 **Green Grass (5722) # _____**

Embroider the leaves.

Thread Color #3 **Bright Yellow (0700) # _____**

Embroider the butterfly wings.

Thread Color #4 **Yellowgreen (6043) # _____**

Embroider the stems.

Thread Color #5 **Liberty Gold (0824) # _____**

Embroider the remaining butterfly wings.

Thread Color #6 **Grasshopper (5933) # _____**

Embroider the under side of the stems and frog.

Thread Color #7 **Cardinal (1904) # _____**

Embroider the lady bug.

Thread Color #8 **Apple Green (5730) # _____**

Embroider the praying mantis.

Thread Color #9 **Black (0020) # _____**

Embroider the outline and future placement line!

Remove the hoop from the module and the fabric from the hoop.

Gently remove the stabilizer from the back. 

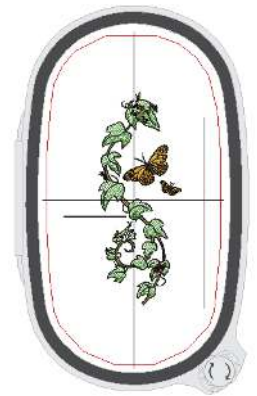

Top of the Fabric

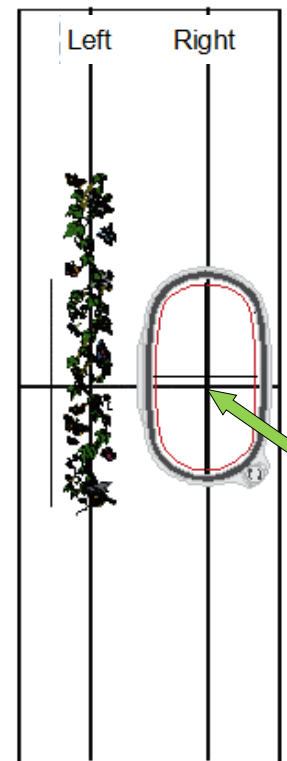

Example #1.



Copyright © 2019 Claudia Dinnell

All rights reserved. No part of this may be reproduced in any form or by any means without written permission from the copyright holder. These designs & instructions are for personal non-commercial use by the original purchaser only and are protected under US & International Laws.

Right Border

Attach the hoop and the grid (no fabric) to the module.

Open #2 Below Center

Step #1 Advance to the **embroidery sewing screen** to go to the 1st stitch of the design.

Step #2 Lower the needle, lay an arrow shaped post it note on the grid with the tip of the arrow touching the needle. (The arrow is positioned about 4" below and slightly to the left of center on the grid)

Fabric Position:

To hoop this design the **Top of the Fabric** is positioned at the top of the hoop.

Hoop the fabric with the **arrow on the grid pointing to the green start arrow**. See green start arrow in **Example #2**.

Remove the grid from the hoop and attach the hoop to the module.

Float a piece of tear away stabilizer (sprayed with 505) **under the attached hoop**.

Thread Color #1 Placement Line:

The needle is positioned at the green start arrow. See **Example #2**.

Sew Color #1 without thread. It sews from the start arrow (at the bottom of the stem) upward to the end arrow following the outline of the leaf. Re-position if needed to follow the outline.

Advance to **Color #2**

Thread Color #2 **Green Grass (5722) #** _____

Embroider the leaves.

Thread Color #3 **White (0015) #** _____

Embroider the bird's neck.

Thread Color #4 **Apple Green (5730) #** _____

Embroider the butterfly wings.

Thread Color #5 **Raspberry (2320) #** _____

Embroider the butterfly wings.

Thread Color #6 **Yellowgreen (6043) #** _____

Embroider the stems.

Thread Color #7 **Liberty Gold (0824) #** _____

Embroider the bird's beak.

Thread Color #8 **Grasshopper (5933) #** _____

Embroider the under side of the stems.

Thread Color #9 **Bright Yellow (0700) #** _____

Embroider the butterfly wings and bees.

Thread Color #10 **Wild Iris (2830) #** _____

Embroider the butterfly wings.

Thread Color #11 **Cornflower Blue (3713) #** _____

Embroider the body of the bird.

Thread Color #12 **Black (0020) #** _____

Embroider the outline and future placement line!

Remove the hoop from the module and the fabric from the hoop.

Gently remove the stabilizer from the back.

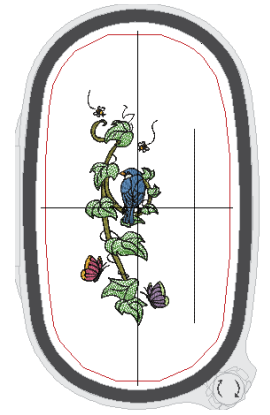

Top of the Fabric

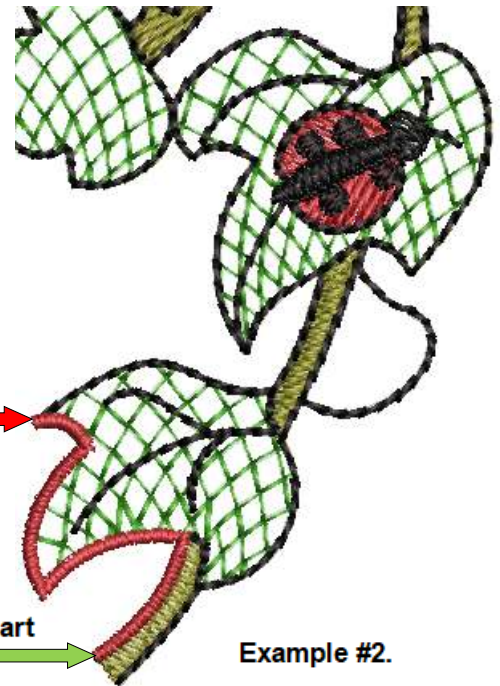

Copyright © 2019 Claudia Dinnell

All rights reserved. No part of this may be reproduced in any form or by any means without written permission from the copyright holder. These designs & instructions are for personal non-commercial use by the original purchaser only and are protected under US & International Laws.

Right Border

Attach the hoop and the grid (no fabric) to the module.

Open #3 Above Center

Step #1 Advance to the **embroidery sewing screen** to go to the 1st stitch of the design.

Step #2 Lower the needle, lay an arrow shaped post it note on the grid with the tip of the arrow touching the needle. (The arrow is positioned about 4 1/2" above and slightly to the left of center on the grid)

Fabric Position:

To hoop this design the **Top of the Fabric** is positioned at the top of the hoop.

Hoop the fabric with the **arrow on the grid pointing to the green start arrow**. See green start arrow in **Example #3**. Placement above the Center hooping. Remove the grid from the hoop and attach the hoop to the module.

Float a piece of tear away stabilizer (sprayed with 505) **under the attached hoop**.

Thread Color #1 Placement Line:

The needle is positioned at the green start arrow. See **Example #3**. Sew Color #1 without thread. It sews from the start arrow (at the top right of the stem) downward around the leaf to the end arrow following the outline of the leaf. Re-position if needed to follow the outline. Advance to **Color #2**

Thread Color #2 **Green Grass (5722) #** _____
Embroider the leaves.

Thread Color #3 **Sterling (0142) #** _____
Embroider the body of the bird.

Thread Color #4 **Yellowgreen (6043) #** _____
Embroider the stems.

Thread Color #5 **Cornflower Blue (3713) #** _____
Embroider the butterfly wings.

Thread Color #6 **Grasshopper (5933) #** _____
Embroider the under side of the stems.

Thread Color #7 **Grape (2910) #** _____
Embroider the smaller butterfly and dragonfly wings.

Thread Color #8 **Chicory (3920) #** _____
Embroider the remaining butterfly wings.

Thread Color #9 **Apple Green (5730) #** _____
Embroider the dragon fly body.

Thread Color #10 **Bright Yellow (0700) #** _____
Embroider the butterfly wings, dragonfly wings and bee.

Thread Color #11 **White (0015) #** _____
Embroider the birds body.

Thread Color #12 **Liberty Gold (0824) #** _____
Embroider the remaining butterfly wings and beak.

Thread Color #13 **Black (0020) #** _____
Embroider the outline and future placement line!

Remove the hoop from the module and the fabric from the hoop. Gently remove the stabilizer from the back.

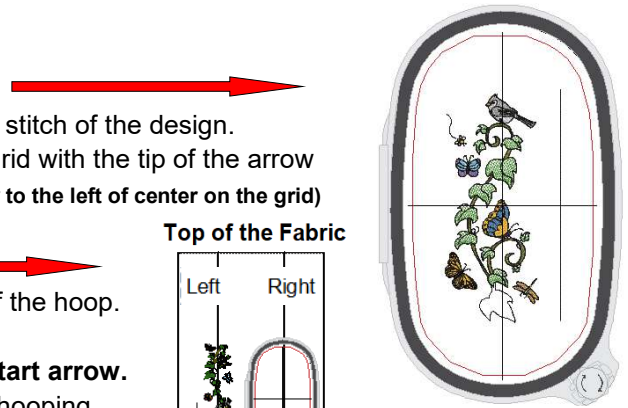

Top of the Fabric

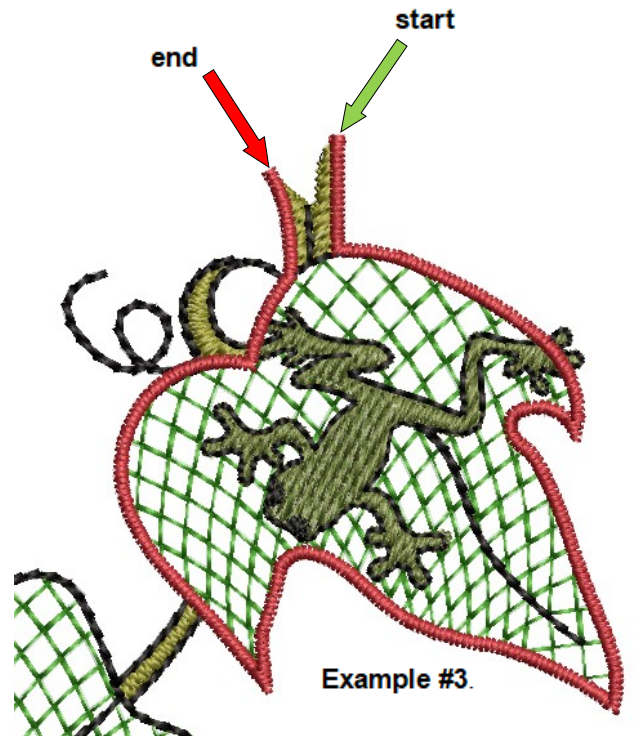
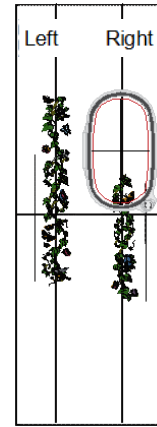

Example #3.



Copyright © 2019 Claudia Dinnell

All rights reserved. No part of this may be reproduced in any form or by any means without written permission from the copyright holder. These designs & instructions are for personal non-commercial use by the original purchaser only and are protected under US & International Laws.

Trimming Embroidered Borders

Remove all the marking from the embroidered borders. (water soluble marks and or iron off pens)
When the marking are removed **press** with **spray starch** and iron flat.

The **stitched in cutting line** on the **outer edge** of the borders is **not** to be cut yet!!

- Draw a vertical line from top to bottom down the **center of each border strip**. See red dotted line.
- Separate the borders by cutting on the newly drawn dotted line.
- Now you have 4 separate borders.



- Draw a new straight **Outer Edge cutting line** over the stitched in line. This will give you a perfectly straight cutting line to work with in case your stitched in line is not perfectly straight. Extend the line the full length of the border strip.
- Draw a line on the **Inner Edge** (edge that is sewn to the **Center Top**) **6 1/2"** opposite of the stitched in **Outer Edge** cutting line. The drawn line is the full length of the border strip.
- Cut **"only"** the **INNER EDGE** side on the borders. See red dotted line in the close up picture. Write **Do Not Cut** above the Outer Edge line on the fabric to help you remember not to cut that side!! The outer edge will be trimmed after the borders are sewn on to the Center Top.
- Align the middle of the **Top Border** (stitched in line) to the middle of the Center Top. The Top Border should be starched then pinned to the **Center Top**. Use many pins to eliminate stretching.
- Use scant quarter inch seams.
Press and starch the seams to the smaller 2" Inner Border.

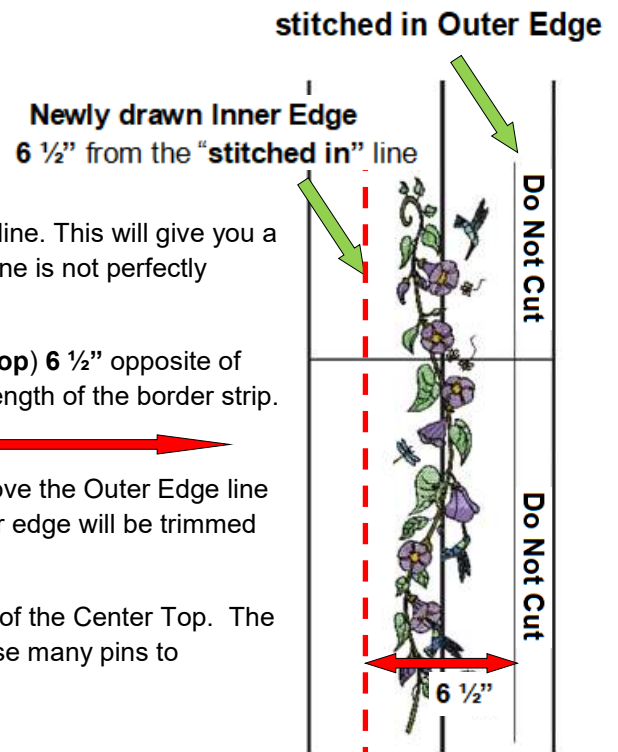

See picture on next page for example.

Copyright © 2019 Claudia Dinnell

All rights reserved. No part of this may be reproduced in any form or by any means without written permission from the copyright holder. These designs & instructions are for personal non-commercial use by the original purchaser only and are protected under US & International Laws.

Trimming Embroidered Borders

Trim the sides of the **Top Border** to the width of the **Center Top**.

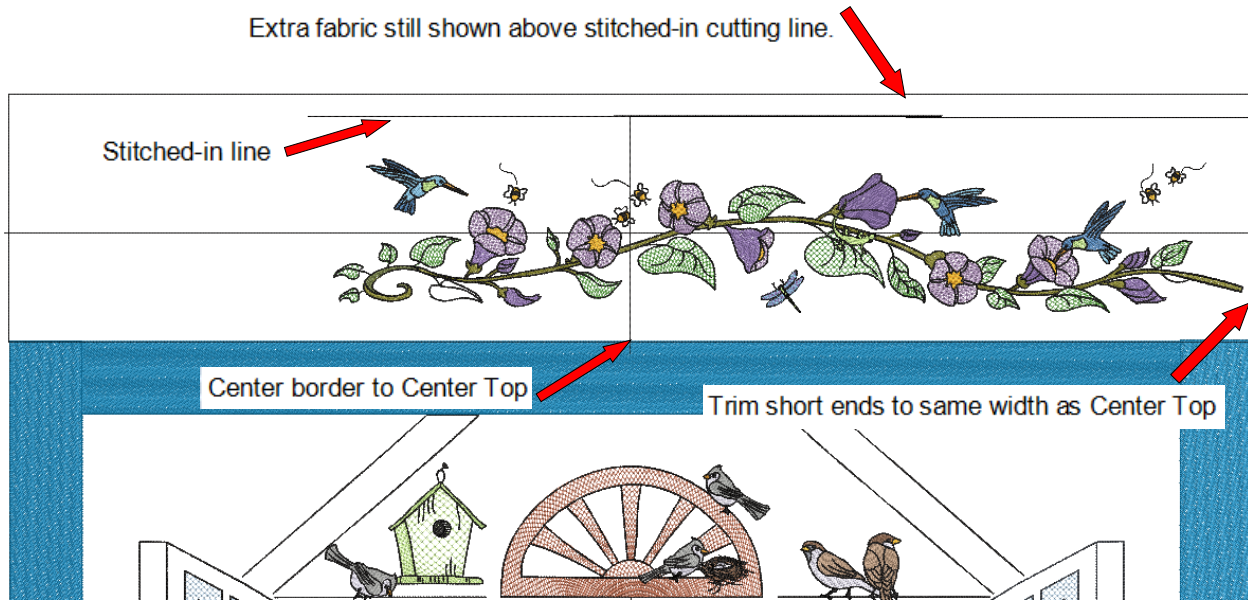

Repeat this process with the Bottom, then the Right and Left Borders. **Remove the basting stitches.**

Trim the quilt top with the embroidered borders to **46 1/2" Square**.

(Embroidered borders will be trimmed about 6 1/4" wide: check your measurements to get 46 1/2" square)

Sub Cut **(4)** 3 1/2" wide strips x 68" from the 16" **Outer Borders Fabric strip**.

Sew a strip to the Top and Bottom of the Quilt Top and then to the Left and Right sides.

Press the seams to the new border. **PRESS THE SEAM FLAT AS YOU CAN!!**

Quilt measures **52 1/2" square**. Remember the stiffness of the quilt will be reduced during the **Blocking** process.



Continue with the embroidered **Corners**.

The added **Outer Borders** will make it easier to embroider the Corners because the fabric will be caught in the hoop!

Copyright © 2019 Claudia Dinnell

All rights reserved. No part of this may be reproduced in any form or by any means without written permission from the copyright holder. These designs & instructions are for personal non-commercial use by the original purchaser only and are protected under US & International Laws.

5 Corners / 1 Lower Right Corner (1 hooping)

Open # 5 Corners / Open 1 Lower Right Corner

Attach the hoop and the grid (no fabric) to the module.



Open Right Corner

Step #1 Advance to the **embroidery sewing screen** to go to the 1st stitch of the design.

Step #2 Lower the needle, lay an arrow shaped post it note on the grid with the tip of the arrow touching the needle. (The arrow is positioned about 4 1/2" above and slightly to the left of center on the grid)

Fabric Position:

To hoop this design the **Top of the Fabric** is positioned at the top of the hoop.

Hoop the fabric with the **arrow on the grid pointing to the green start arrow**. See green start arrow in **Example #1**. Positioned at the lower right corner off the Inner Border. Remove the grid. Attach the hoop to the module.

Float a piece of tear away stabilizer (sprayed with 505) **under the attached hoop**.

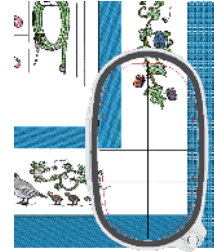

Thread Color #1 Placement Line:

The needle is positioned at the green start arrow. See **Example #1**.

Sew Color #1 without thread. It sews from the start arrow (lower right corner of the Inner Border) up 4" to the end arrow following the ditch of the seam.

Advance to **Color #2**

Thread Color #2 **Green Grass (5722) #** _____

Embroider the leaves.

Thread Color #3 **Chicory (3920) #** _____

Embroider the butterfly wings.

Thread Color #4 **Cardinal (1904) #** _____

Embroider the lady bug.

Thread Color #5 **Cornflower Blue (3713) #** _____

Embroider the butterfly wings.

Thread Color #6 **Yellowgreen (6043) #** _____

Embroider the stems.

Thread Color #7 **Wild Iris (2830) #** _____

Embroider the remaining butterfly wings.

Thread Color #8 **Apple Green (5730) #** _____

Embroider the dragon fly body.

Thread Color #9 **Grasshopper (5933) #** _____

Embroider the under side of the stems.

Thread Color #10 **Bright Yellow (0700) #** _____

Embroider the dragonfly wings & bee.

Thread Color #11 **Black (0020) #** _____

Embroider the outline.

Thread Color #12 **Sterling (0142) #** _____

Embroider the spider web.

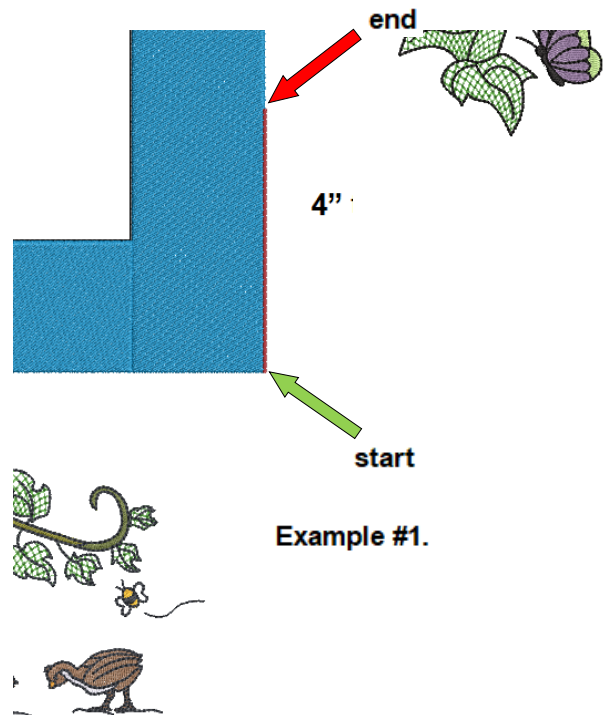

Example #1.

Remove the hoop from the module and the fabric from the hoop.

Gently remove the stabilizer from the back.



Copyright © 2019 Claudia Dinnell

All rights reserved. No part of this may be reproduced in any form or by any means without written permission from the copyright holder. These designs & instructions are for personal non-commercial use by the original purchaser only and are protected under US & International Laws.

5 Corners / 2 Upper Right Corner (1 hooping)

Open # 2 Upper Right Corner Folder

Attach the hoop and the grid (no fabric) to the module.

Open Birdhouse

Step #1 Advance to the **embroidery sewing screen** to go to the 1st stitch of the design.

Step #2 Lower the needle, lay an arrow shaped post it note on the grid with the tip of the arrow touching the needle. (The arrow is positioned about 4 ½" above and slightly to the left of center on the grid)

Fabric Position:

To hoop this design the **Top of the Fabric** is positioned at the top of the hoop.

Hoop the fabric with the **arrow on the grid pointing to the green start arrow**. See green start arrow in **Example #2**. Remove the grid. Attach the hoop. **Float a piece of tear away stabilizer** (sprayed with 505) **under the attached hoop**.



Thread Color #1 Placement Line:

The needle is positioned at the green start arrow. See **Example #2**. Sew Color #1 without thread. It sews from the start arrow (bottom right end of the stem) to the end arrow following the stem. Advance to **Color #2**

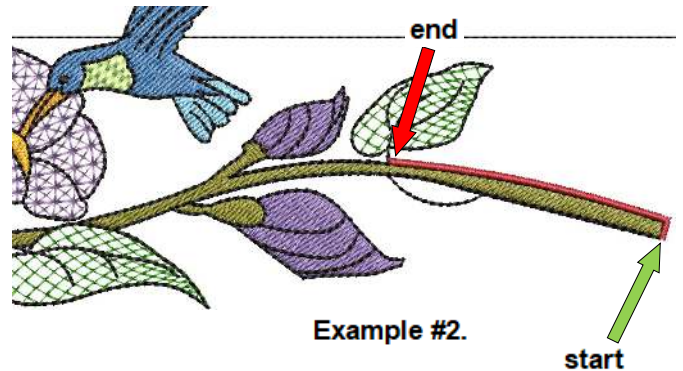

Thread Color #2 **Green Grass (5722) # _____**

Embroider the basting stitches & leaves.

Thread Color #3 **Nutmeg (0932) # _____**

Embroider the bird house.

Thread Color #4 **Heather Pink (2152) # _____**

Embroider the roof.

Thread Color #5 **Yellowgreen (6043) # _____**

Embroider the stems.

Thread Color #6 **White (0015) # _____**

Embroider the trim on the hole and bird's chest.

Thread Color #7 **Sterling (0142) # _____**

Embroider the body of the bird.

Thread Color #8 **Liberty Gold (0824) # _____**

Embroider the bird's beak.

Thread Color #9 **Apple Green (5730) # _____**

Embroider the praying mantis body.

Thread Color #10 **Grape (2910) # _____**

Embroider the flower bud.

Thread Color #11 **Black (0020) # _____**

Embroider the outline.

Thread Color #12 **Raspberry (2320) # _____**

Embroider the remaining trim on hole.

Remove the hoop from the module and the fabric from the hoop.

Gently remove the stabilizer from the back.

Remove the basting stitches.

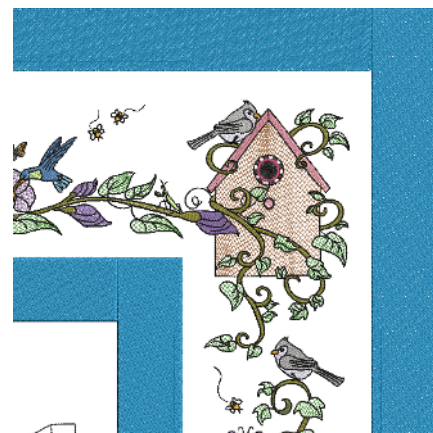

Copyright © 2019 Claudia Dinnell

All rights reserved. No part of this may be reproduced in any form or by any means without written permission from the copyright holder. These designs & instructions are for personal non-commercial use by the original purchaser only and are protected under US & International Laws.

5 Corners /3 Upper Left Corner (2 hoopings)

Open #3 Upper Left Corner Folder

Attach the hoop and the grid (no fabric) to the module.

Open #1 Bird & Dragonflies

Step #1 Advance to the **embroidery sewing screen** to go to the 1st stitch of the design.

Step #2 Lower the needle, lay an arrow shaped post it note on the grid with the tip of the arrow touching the needle. (The arrow is positioned about 3 1/2" above and 2 1/2" to the left of center on the grid)

Fabric Position:

To hoop this design the **Top of the Fabric** is rotated to the right of the hoop.

Hoop the fabric with the **arrow on the grid pointing to the green start arrow**, see green start arrow in **Example #1**. Remove the grid.

Attach the hoop and **float a piece of tear away stabilizer** (sprayed with 505) **under the attached hoop**.

Thread Color #1 Placement Line:

The needle is positioned at the green start arrow
See **Example #1**. Sew Color #1 without thread.
It sews from the start arrow (outside corner edge)
to the end arrow (6" down) following the ditch of the seam.
Advance to **Color #2**

Thread Color #2 **Green Grass (5722) # _____**

Embroider the leaves.

Thread Color #3 **Grape (2910) # _____**

Embroider the dragonfly wings.

Thread Color #4 **Yellowgreen (6043) # _____**

Embroider the stems.

Thread Color #5 **Liberty Gold (0824) # _____**

Embroider the dragonfly wings.

Thread Color #6 **Chicory (3920) # _____**

Embroider the lacework fill on the wings.

Thread Color #7 **Grasshopper (5933) # _____**

Embroider the lining of the stems.

Thread Color #8 **Bright Yellow (0700) # _____**

Embroider the bird's beak and lacework fill on the wings.

Thread Color #9 **Redwood (0933) # _____**

Embroider the bird's head.

Thread Color #10 **White (0015) # _____**

Embroider the bird's neck.

Thread Color #11 **Carmel Cream (1123) # _____**

Embroider the bird's body.

Thread Color #12 **Apple Green (5730) # _____**

Embroider the dragonfly bodies.

Thread Color #13 **Black (0020) # _____**

Embroider the outline.

Remove the hoop from the module and the fabric from the hoop.

Gently remove the stabilizer from the back.

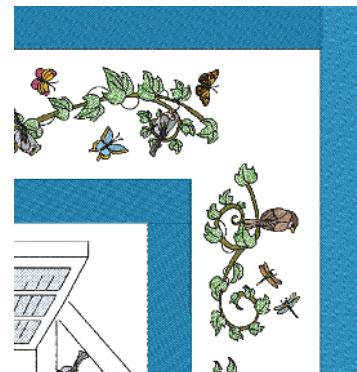
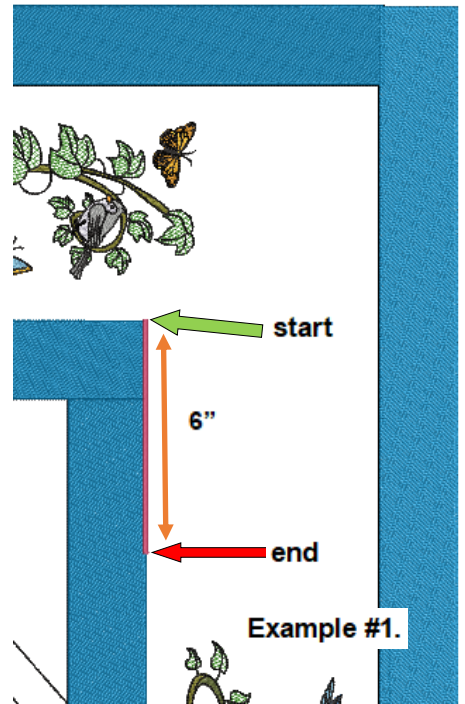
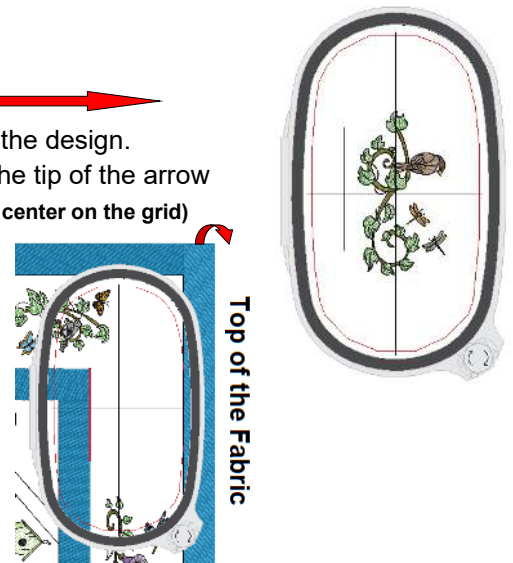

Copyright © 2019 Claudia Dinnell

All rights reserved. No part of this may be reproduced in any form or by any means without written permission from the copyright holder. These designs & instructions are for personal non-commercial use by the original purchaser only and are protected under US & International Laws.

5 Corners / 3 Upper Left Corner

Attach the hoop and the grid (no fabric) to the module.

Open #2 Corner

Step #1 Advance to the **embroidery sewing screen** to go to the 1st stitch of the design.

Step #2 Lower the needle, lay an arrow shaped post it note on the grid with the tip of the arrow touching the needle. (The arrow is positioned about 1 1/2" above and 1" to the left of center on the grid)

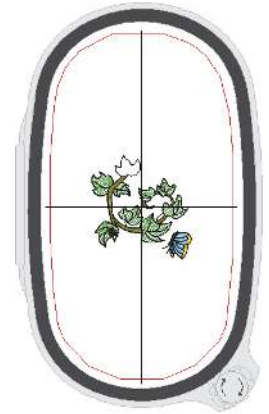

Fabric Position:

To hoop this design the **Top of the Fabric** is positioned at the **BOTTOM** of the hoop.

Quilt is upside down!!



Hoop the fabric with the **arrow on the grid pointing to the green start arrow**. See green start arrow in **Example #2**. Remove the grid. Attach the hoop.
Float a piece of tear away stabilizer (sprayed with 505) **under the attached hoop**.

Thread Color #1 Placement Line:

The needle is positioned at the green start arrow. See **Example #2**. Sew Color #1 without thread. It sews from the start arrow (the center of the leaf) up and around the leaf then back to the start mark) to the end arrow following the stem. Placement line shown in red.

Advance to **Color #2**

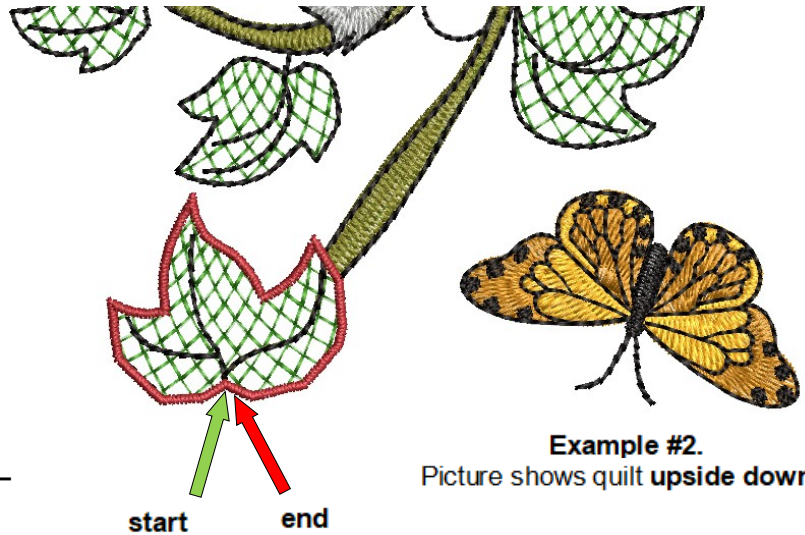

Example #2.
Picture shows quilt **upside down!**

Thread Color #2 **Green Grass (5722) # _____**

Embroider the leaves.

Thread Color #3 **Bright Yellow (0700) # _____**

Embroider the tip of the butterfly wings.

Thread Color #4 **Yellowgreen (6043) # _____**

Embroider the stems.

Thread Color #5 **Chicory (3920) # _____**

Embroider the butterfly body.

Thread Color #6 **Cardinal (1904) # _____**

Embroider the lady bug.

Thread Color #7 **Black (0020) # _____**

Embroider the outline.

Remove the hoop from the module and the fabric from the hoop.

Gently remove the stabilizer from the back.

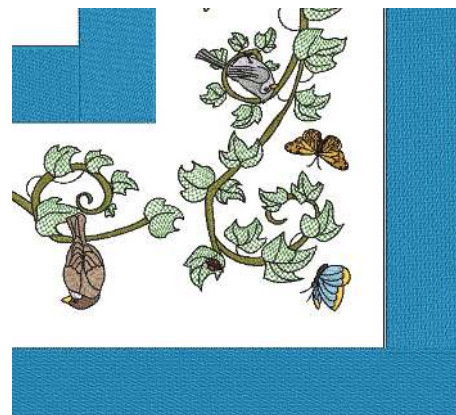

Picture shows quilt **upside down!**

Copyright © 2019 Claudia Dinnell

All rights reserved. No part of this may be reproduced in any form or by any means without written permission from the copyright holder. These designs & instructions are for personal non-commercial use by the original purchaser only and are protected under US & International Laws.

5 Corners / 4 Lower Left Corner (2 hoopings)

Open # 4 Lower Left Corner Folder

Attach the hoop and the grid (no fabric) to the module.

Open #1 Beehive

Step #1 Advance to the **embroidery sewing screen** to go to the 1st stitch of the design.

Step #2 Lower the needle, lay an arrow shaped post it note on the grid with the tip of the arrow touching the needle. (The arrow is positioned about 1/2" above and 3 1/2" to the right of center on the grid)

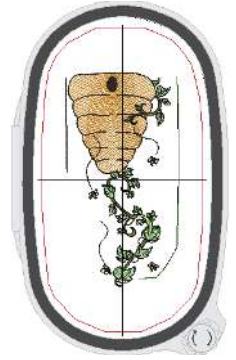

Fabric Position:

To hoop this design the **Top of the Fabric** is positioned at the **BOTTOM** of the hoop.

Quilt is upside down!!

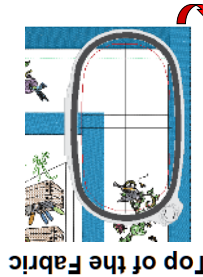

Hoop the fabric with the **arrow on the grid pointing to the green start arrow**, see green start arrow in **Example #1**. Remove the grid.

Attach the hoop and **float a piece of tear away stabilizer** (sprayed with 505) **under the attached hoop**.

Thread Color #1 Placement Line:

The needle is positioned at the green start arrow
See **Example #1**. Sew Color #1 without thread.
It sews from the start arrow (outside corner edge)
to the end arrow (**5"** up) following the ditch of the seam.
Advance to **Color #2**

Thread Color #2 **Liberty Gold (0824) # _____**
Embroider the beehive.

Thread Color #3 **Green Grass (5722) # _____**
Embroider the leaves.

Thread Color #4 **Bright Yellow (0700) # _____**
Embroider the bees.

Thread Color #5 **Yellowgreen (6043) # _____**
Embroider the stems.

Thread Color #6 **Apple Green (5730) # _____**
Embroider the lizard.

Thread Color #7 **Grasshopper (5933) # _____**
Embroider the lining of the stems.

Thread Color #8 **Black (0020) # _____**
Embroider the outline.

Quilt top is upside down.

Remove the hoop from the module

and the fabric from the hoop.

Gently remove the stabilizer from the back.

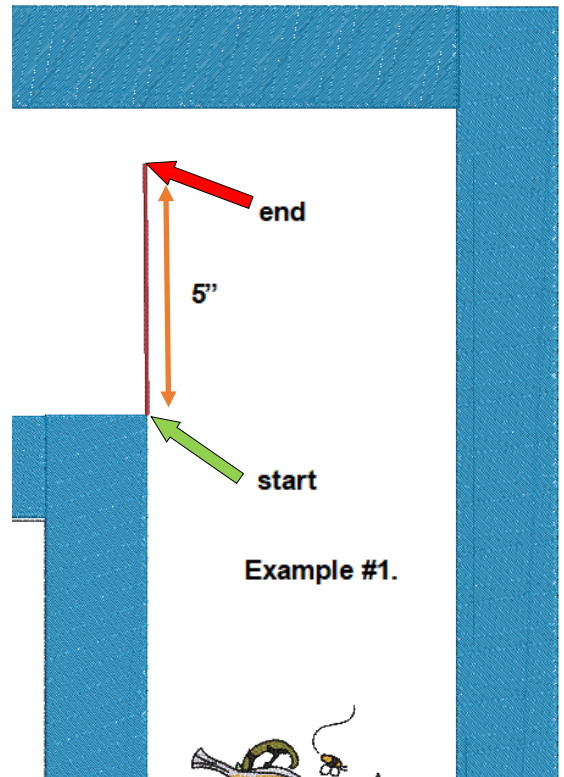
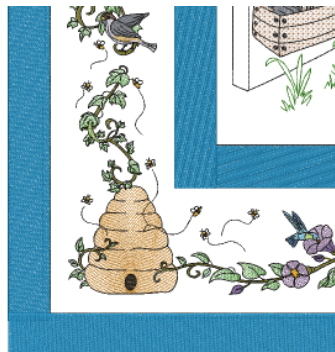

Copyright © 2019 Claudia Dinnell

All rights reserved. No part of this may be reproduced in any form or by any means without written permission from the copyright holder. These designs & instructions are for personal non-commercial use by the original purchaser only and are protected under US & International Laws.

5 Corners / 4 Lower Left Corner

Attach the hoop and the grid (no fabric) to the module.

Open #2 Bees & Flowers

Step #1 Advance to the **embroidery sewing screen** to go to the 1st stitch of the design.

Step #2 Lower the needle, lay an arrow shaped post it note on the grid with the tip of the arrow touching the needle. (The arrow is positioned about 3 1/2" above and 2 1/2" to the left of center on the grid)

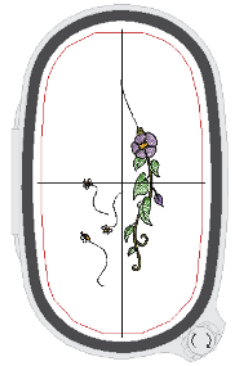

Fabric Position:

To hoop this design the **Top of the Fabric** is positioned to the **LEFT** of the hoop.

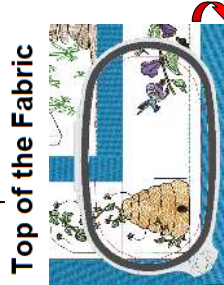

Hoop the fabric with the **arrow on the grid pointing to the green start arrow**, see green start arrow in **Example #2**. Remove the grid. Attach the hoop and **float a piece of tear away stabilizer** (sprayed with 505) **under the attached hoop**.

Thread Color #1 Placement Line:

The needle is positioned at the green start arrow. See **Example #2**. Sew Color #1 without thread. It sews from the start arrow (bottom of the stem) to the end arrow following the outline of the stem. Advance to **Color #2**

Thread Color #2 **Green Grass (5722) # _____**

Embroider the leaves.

Thread Color #3 **Purple (2910) # _____**

Embroider the base of the flowers.

Thread Color #4 **Yellowgreen (6043) # _____**

Embroider the stems.

Thread Color #5 **Wild Iris (2830) # _____**

Embroider the top of the flower.

Thread Color #6 **Bright Yellow (0700) # _____**

Embroider the bees.

Thread Color #7 **Black (0020) # _____**

Embroider the outline.

Note:

This design may or may not actually embroider over the beehive. It will still line up beautifully either way. It depends on the stretch of your fabric!

Remove the hoop from the module and the fabric from the hoop.

Gently remove the stabilizer from the back.

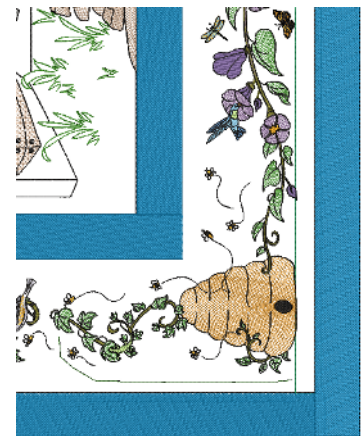
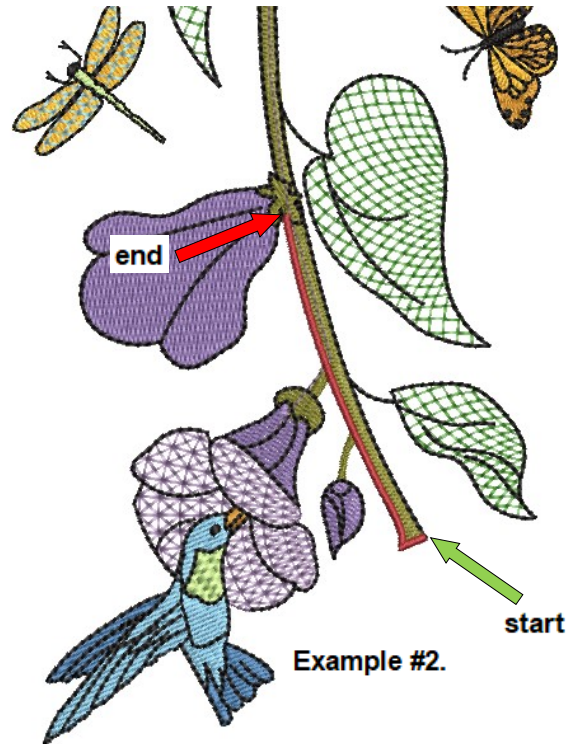

Copyright © 2019 Claudia Dinnell

All rights reserved. No part of this may be reproduced in any form or by any means without written permission from the copyright holder. These designs & instructions are for personal non-commercial use by the original purchaser only and are protected under US & International Laws.

3 Wheelbarrow
3 Wheelbarrow / 1 Bottom (3 hooping)

Open # 3 Wheelbarrow

Attach the hoop and the grid (no fabric) to the module.

Note: Larger Hoops select Combo Folder:

First design 9 1/2" wide hoops Second design 10"+ wide hoops

Follow pages 49-50 for thread colors.

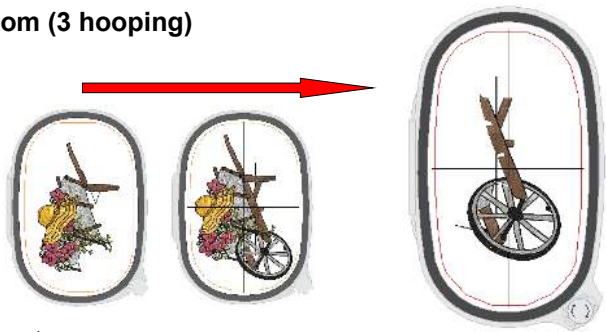

Open 1 Bottom

Step #1 Advance to the **embroidery sewing screen** to go to the 1st stitch of the design.

Step #2 Lower the needle, lay an arrow shaped post it note on the grid with the tip of the arrow touching the needle. (The arrow is positioned about 5 1/2" above and 1/2" to the left of center on the grid)

Fabric Position:

To hoop this design the **Top of the Fabric** is positioned to the **LEFT** of the hoop.

First: Mark the Fabric.

Draw a removable line 1" inside the Lower Right Corner.



Hoop the fabric with the **arrow on the grid pointing to the green start arrow, see green start arrow in Example #1.** Remove the grid. Attach the hoop and **float a piece of tear away stabilizer** (sprayed with 505) **under the attached hoop.**

Thread Color #1 Placement Line:

The needle is positioned at the green start arrow See **Example #1.** Sew Color #1 without thread. It sews from the start arrow down the ditch of the seam 8" to the end arrow. **NOTE:** If you added a **Quarter Inch Border**, be sure to align the needle in the **ditch touching the Outer Border** (not Quarter Inch Border).

Advance to **Color #2**

Thread Color #2 **Sterling (0142) # _____**

Embroider the wheel base.

Thread Color #3 **Cardinal (1904) # _____**

Embroider the lady bug.

Thread Color #4 **Redwood (0933) # _____**

Embroider the wheelbarrow base.

Thread Color #5 **Black (0020) # _____**

Embroider the outlining.

Remove the hoop from the module

and the fabric from the hoop.

Gently remove the stabilizer from the back.

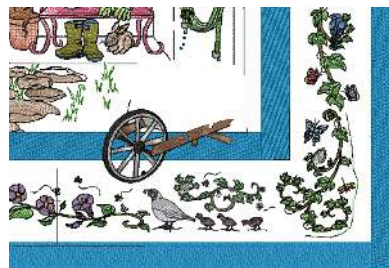
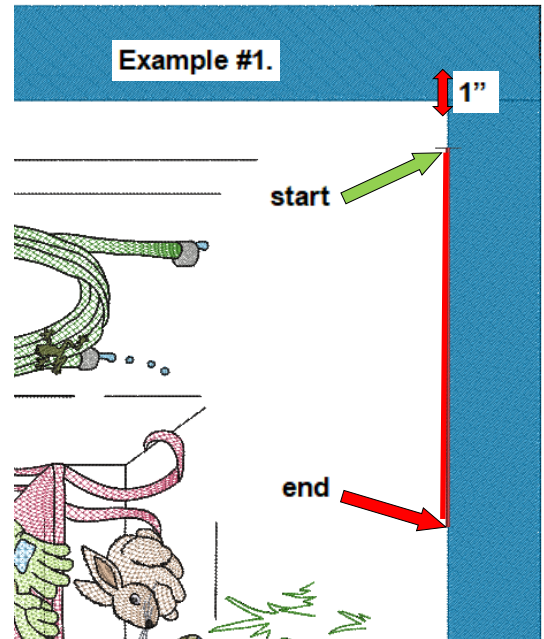

Copyright © 2019 Claudia Dinnell

All rights reserved. No part of this may be reproduced in any form or by any means without written permission from the copyright holder. These designs & instructions are for personal non-commercial use by the original purchaser only and are protected under US & International Laws.

3 Wheelbarrow / 2 Top Wheelbarrow

Attach the hoop and the grid (no fabric) to the module.

Open 2 Top of Wheelbarrow

Step #1 Advance to the **embroidery sewing screen** to go to the 1st stitch of the design.

Step #2 Lower the needle, lay an arrow shaped post it note on the grid with the tip of the arrow touching the needle. (The arrow is positioned about 4 1/2" below and 1/2" to the right of center on the grid)

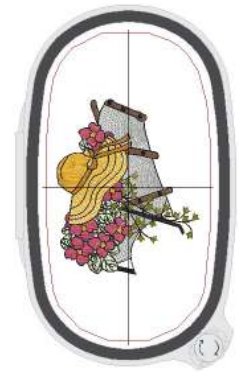

Fabric Position:

To hoop this design the **Top of the Fabric** is positioned to the **LEFT** of the hoop.

Same as last hooping.

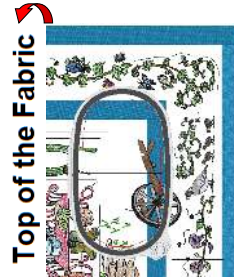

Hoop the fabric with the **arrow on the grid pointing to the green start arrow, see green start arrow in Example #2.**
Remove the grid. Attach the hoop and **float a piece of tear away stabilizer (sprayed with 505) under the attached hoop.**

Thread Color #1 Placement Line:

The needle is positioned at the green start arrow

See **Example #2.** Sew Color #1 without thread.

It sews from the start arrow up the outline of the wheelbarrow base to the end arrow.

Advance to **Color #2**

Thread Color #2 **Sterling (0142) # _____**

Embroider the wheel base.

Thread Color #3 **Redwood (0933) # _____**

Embroider the wheelbarrow frame.

Thread Color #4 **Apple Green (5730) # _____**

Embroider the greenery.

Thread Color #5 **Raspberry (2320) # _____**

Embroider the flowers.

Thread Color #6 **Bright Yellow (0700) # _____**

Embroider the hat.

Thread Color #7 **Liberty Gold (0824) # _____**

Embroider the ribbon on hat.

Thread Color #8 **Black (0020) # _____**

Embroider the outlining.

Thread Color #9 **Yellowgreen (6043) # _____**

Embroider the ivy.

Thread Color #10 **Black (0020) # _____**

Embroider the remaining outlining.

Remove the hoop from the module

and the fabric from the hoop.

Gently remove the stabilizer from the back.

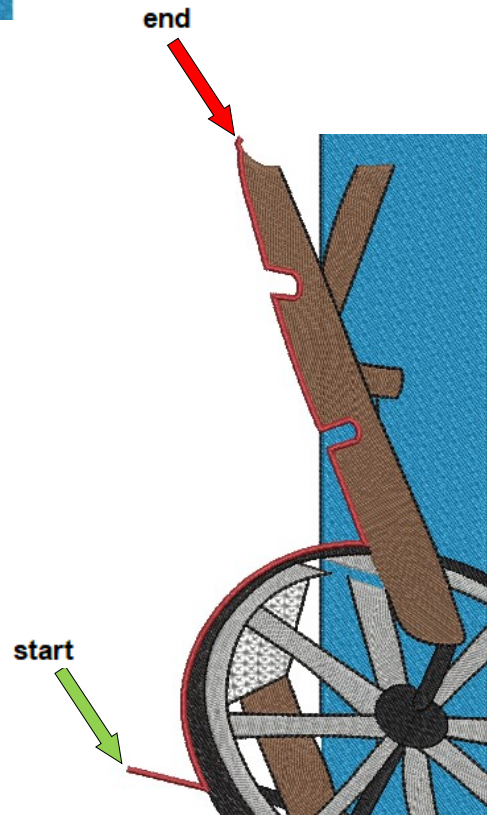

Example #2.



Copyright © 2019 Claudia Dinnell

All rights reserved. No part of this may be reproduced in any form or by any means without written permission from the copyright holder. These designs & instructions are for personal non-commercial use by the original purchaser only and are protected under US & International Laws.

3 Wheelbarrow / 3 Handle

Attach the hoop and the grid (no fabric) to the module.

Open 3 Handle

Step #1 Advance to the **embroidery sewing screen** to go to the 1st stitch of the design.

Step #2 Lower the needle, lay an arrow shaped post it note on the grid with the tip of the arrow touching the needle. (The arrow is positioned about 4 1/2" below and 1/2" to the right of center on the grid)

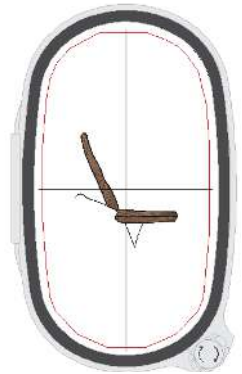

Fabric Position:

To hoop this design the **Top of the Fabric** is positioned to the **LEFT** of the hoop.

Same as last hooping.

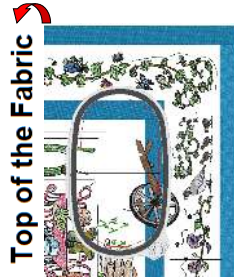

Hoop the fabric with the **arrow on the grid pointing to the green start arrow**, see green start arrow in **Example #3**. Remove the grid. Attach the hoop and **float a piece of tear away stabilizer** (sprayed with 505) **under the attached hoop**.

Thread Color #1 Placement Line:

The needle is positioned at the green start arrow See **Example #3**. Sew Color #1 without thread. It sews from the start arrow to the left across the base of the wheelbarrow to the end arrow following the outline of the design.

Advance to Color #2

Thread Color #2 **Redwood (0933) # _____**
Embroider the wheelbarrow handle.

Thread Color #3 **Black (0020) # _____**
Embroider the outlining.

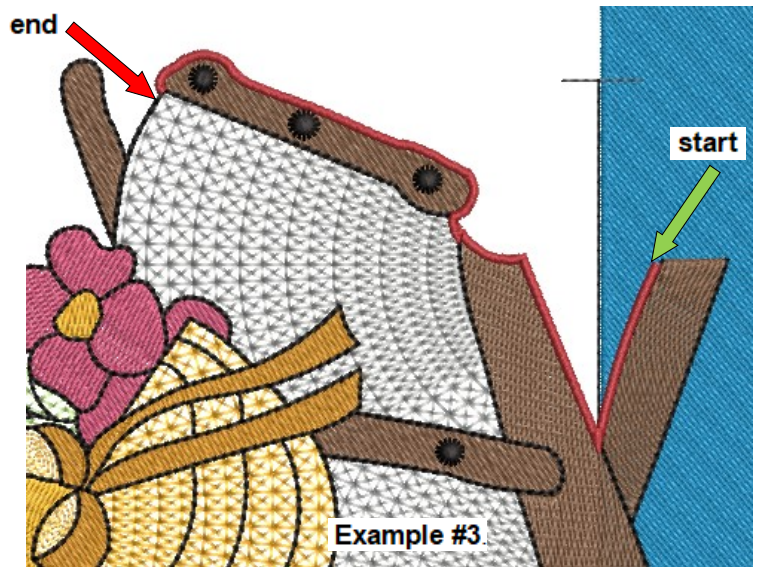

Remove the hoop from the module and the fabric from the hoop. Gently remove the stabilizer from the back.

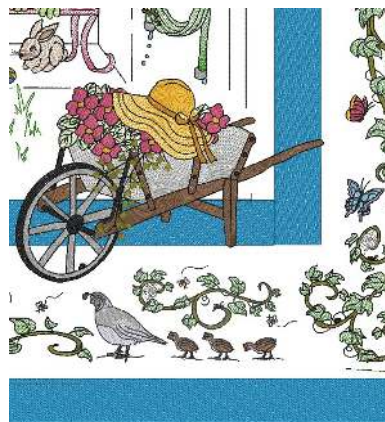

Continue with the Sayings for Inner Borders.

Copyright © 2019 Claudia Dinnell

All rights reserved. No part of this may be reproduced in any form or by any means without written permission from the copyright holder. These designs & instructions are for personal non-commercial use by the original purchaser only and are protected under US & International Laws.

4 Sayings for Inner Borders

Mark each of the Inner Borders (use a pen with removable ink) before embroidering the saying.

Draw a **Center Crosshair** on the **Top, Right, and Left** Inner Blue Borders.
The lines should be the full width and height of the Blue Border.

Bottom Border:

Measure the distance between the wheel (on the Wheelbarrow) and the left end of the Bottom Border.
See the marking on the diagram below.
My measurement was almost 20". Divide that measurement by half. That is your center mark.

20" wide, minus half that measurement 10" = 10"

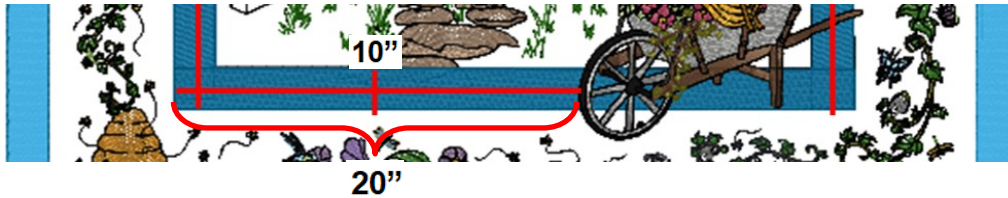

Each verse will start on a
Center Crosshair!



Copyright © 2019 Claudia Dinnell

All rights reserved. No part of this may be reproduced in any form or by any means without written permission from the copyright holder. These designs & instructions are for personal non-commercial use by the original purchaser only and are protected under US & International Laws.

www.claudiascreationsaz.com

4 Sayings for Inner Borders

Attach the hoop and the grid (no fabric) to the module.

You may want to match the bobbin thread to the top thread while embroidering words.

Open 4 Sayings for Borders

Open 1 Top Border

Open #1 season, a time to plant

Step #1 Advance to the **embroidery sewing screen** to go to the 1st stitch of the design.

Step #2 Lower the needle, lay an arrow shaped post it note on the grid with the tip of the arrow touching the needle. (The arrow is positioned about 1/2" above and slightly to the left of center on the grid)

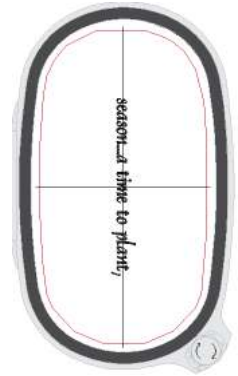

Fabric Position:

To hoop this design the **Top of the Fabric** is positioned to the **Right** of the hoop.

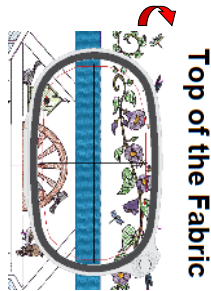

Hoop the fabric with the **arrow on the grid pointing to the newly drawn Center Crosshair on the Top Border**. See green start arrow in **Example #3**. Remove the grid. Attach the hoop and **float a piece of tear away stabilizer** (sprayed with 505) **under the attached hoop**.

Thread Color #1 Needle Alignment:

The needle is positioned at the green start arrow on the center crosshair. See **Example #1**. Do not sew Color #1, it is a needle alignment only. Advance to **Color #2**

Thread Color #2 Placement Line:

Sew Color #2 without thread. It sews from the upper to the lower area of the hoop following the line you drew. **Rotate** the design if needed to follow the drawn line. If you rotated, go back to Color #1 to make sure you are still on the center mark. This will assure that you are straight on the border. Advance to **Color #3**.

Thread Color #3 Bright Yellow (0700) # _____
Embroider the verse.

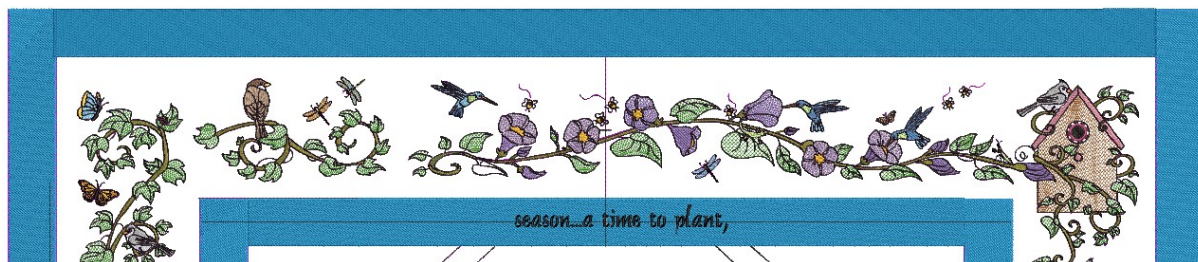
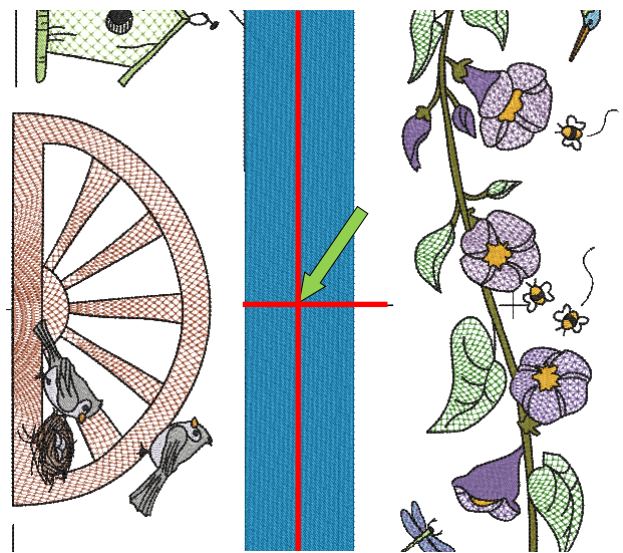

Remove the hoop from the module and the fabric from the hoop.
Gently remove the stabilizer from the back.

Copyright © 2019 Claudia Dinnell

All rights reserved. No part of this may be reproduced in any form or by any means without written permission from the copyright holder. These designs & instructions are for personal non-commercial use by the original purchaser only and are protected under US & International Laws.

Attach the hoop and the grid (no fabric) to the module.

1 Top Border

Open 2 To everything there is a

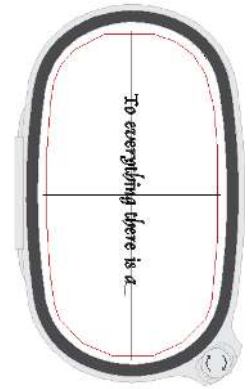

Step #1 Advance to the **embroidery sewing screen** to go to the 1st stitch of the design.

Step #2 Lower the needle, lay an arrow shaped post it note on the grid with the tip of the arrow touching the needle. (The arrow is positioned about 4 1/2" above and slightly to the left of center on the grid)

Fabric Position:

To hoop this design the **Top of the Fabric** is positioned to the **Right** of the hoop.

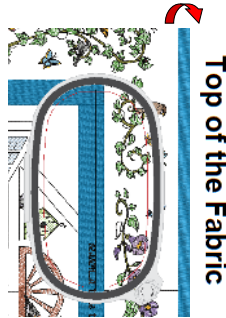

Hoop the fabric with the **arrow on the grid pointing to the bottom center of the "s" in the word season.**

See green start arrow in Example #2. Remove the grid. Attach the hoop and **float a piece of tear away stabilizer** (sprayed with 505) **under the attached hoop.**

Thread Color #1 Needle Alignment:

The needle is positioned at the green start arrow

See **Example #3.** Do not sew Color #1, it is a needle alignment only.

Advance to **Color #2**

Thread Color #2 Placement Line:

Sew Color #2 without thread. It sews from the lower to the upper area of the hoop following the line you drew. **Rotate** the design if needed to follow the drawn line. If you rotated, go back to Color #1 to make sure you are at the starting point. This will assure that you are straight on the border. Advance to **Color #3.**

Thread Color #3 **Bright Yellow (0700) # _____**

Embroider the verse.

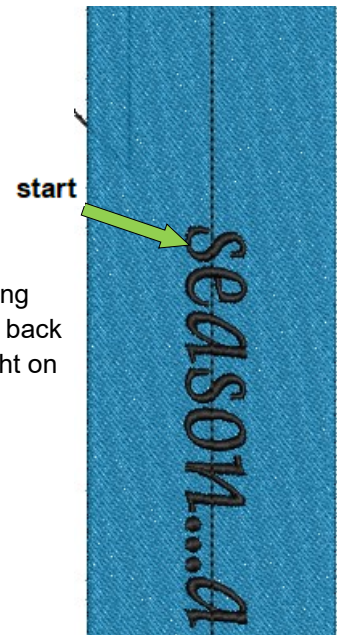

Example #2.



Remove the hoop from the module and the fabric from the hoop.

Gently remove the stabilizer from the back.

Copyright © 2019 Claudia Dinnell

All rights reserved. No part of this may be reproduced in any form or by any means without written permission from the copyright holder. These designs & instructions are for personal non-commercial use by the original purchaser only and are protected under US & International Laws.

Attach the hoop and the grid (no fabric) to the module.

1 Top Border

Open 3 and a time to pluck

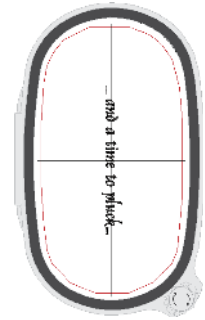

Step #1 Advance to the **embroidery sewing screen** to go to the 1st stitch of the design.

Step #2 Lower the needle, lay an arrow shaped post it note on the grid with the tip of the arrow touching the needle. (The arrow is positioned about 4 1/2" above and slightly to the left of center on the grid)

Fabric Position:

To hoop this design the **Top of the Fabric** is positioned to the **Right** of the hoop.

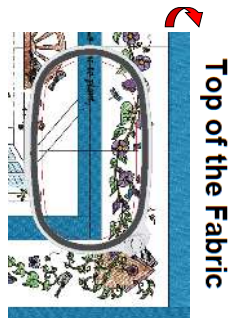

Hoop the fabric with the **arrow on the grid pointing to the center bottom of the "t" in the word plant.**

See green start arrow in Example #3. Remove the grid. Attach the hoop and **float a piece of tear away stabilizer** (sprayed with 505) **under the attached hoop.**

Thread Color #1 Needle Alignment:

The needle is positioned at the green start arrow

See **Example #3.** Do not sew Color #1, it is a needle alignment only.

Advance to **Color #2**

Thread Color #2 Placement Line:

Sew Color #2 without thread. It sews from the upper to the lower area of the hoop following the line you drew. **Rotate** the design if needed to follow the drawn line. If you rotated, go back to Color #1 to make sure you are at the starting point. This will assure that you are straight on the border. Advance to **Color #3.**

Thread Color #3 **Bright Yellow (0700) # _____**

Embroider the verse.



Example #3.



Remove the hoop from the module and the fabric from the hoop.

Gently remove the stabilizer from the back.

Copyright © 2019 Claudia Dinnell

All rights reserved. No part of this may be reproduced in any form or by any means without written permission from the copyright holder. These designs & instructions are for personal non-commercial use by the original purchaser only and are protected under US & International Laws.

Right Border

Repeat the same process for embroidering the Right Border.

1. Line up first stitch
2. Sew Placement line without thread (for straightness)
3. Embroider the words

Fabric Position:

Top of the Quilt is positioned at the **top of the hoop** for all 3 hoopings.

Open 2 Right Border

Open #1 harvest love &

First stitch: the needle is positioned at the center crosshair on the **Right Border**. See green start arrow in **Example #1**.

Color #2: Sew Placement Line without thread!

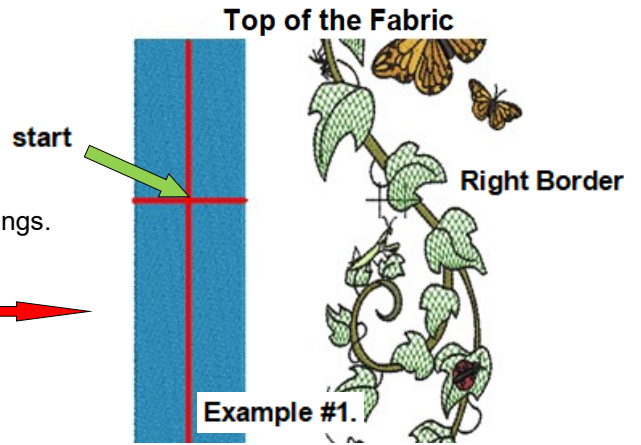

Open #2 Plant smiles, grow Laughter,

First stitch: the needle is positioned at the center bottom of the "first stem" on the letter "h" in the word harvest. That location on the "h" represents the bottom of the lower case letters. See green start arrow in **Example #2**.



Open 3 bloom with grace.

First stitch: the needle is positioned at the center bottom of the ampersand symbol. See green start arrow in **Example 3**.

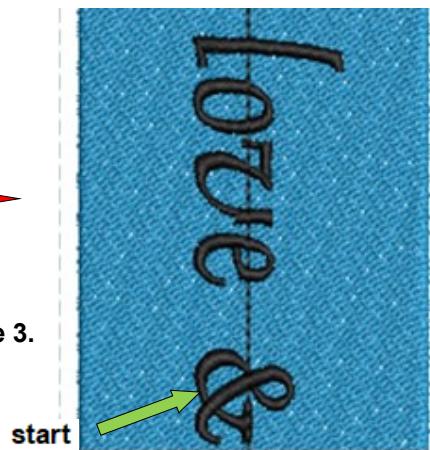

Copyright © 2019 Claudia Dinnell

All rights reserved. No part of this may be reproduced in any form or by any means without written permission from the copyright holder. These designs & instructions are for personal non-commercial use by the original purchaser only and are protected under US & International Laws.

Bottom Border

Repeat the same process for embroidering the Bottom Borders.

1. Line up first stitch
2. Sew Placement line without thread (for straightness)
3. Embroider the words

Fabric Position:

Top of the Quilt is positioned at the LEFT of the hoop for both of the hoopings.

Note: Larger Hoops select **Combo Folder**:
Select the Full design in one hooping!
Follow Example #1 for first stitch alignment.



Top of the Fabric

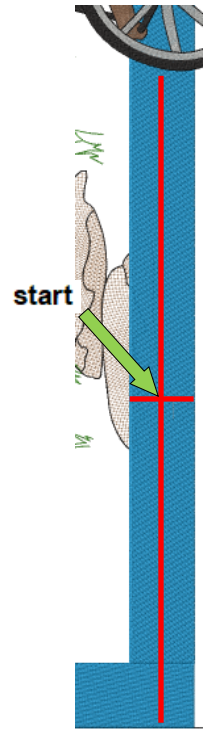

Example #1.

Open 2 Bottom Border
Open #1 So many seeds

First stitch: the needle is positioned at the newly drawn center crosshair on the **Bottom Border**. See green start arrow in **Example #1**.

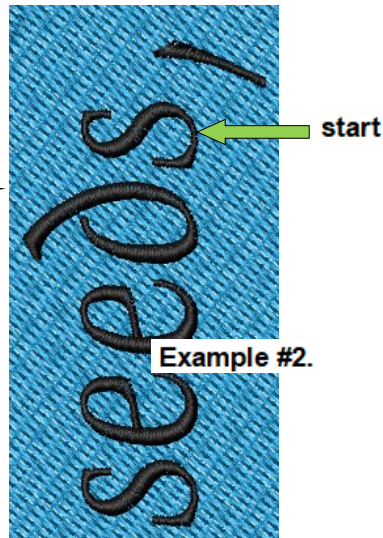

Example #2.

Open #2 so little thyme!

First stitch: the needle is positioned at the center bottom of the last "s" in the word seeds. See green start arrow in **Example #2**.

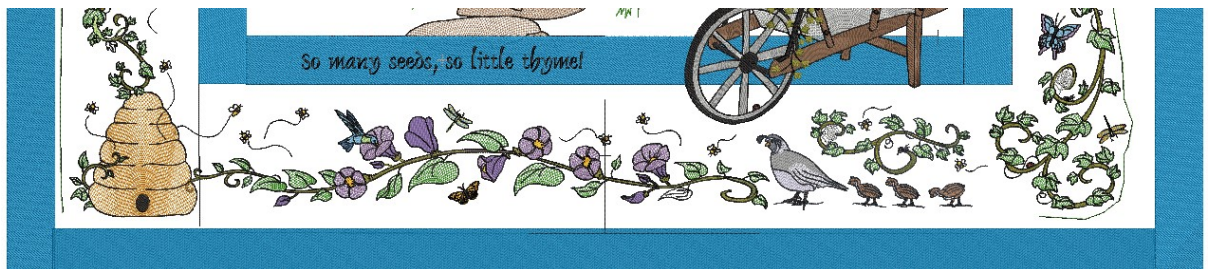

Finished Border

Copyright © 2019 Claudia Dinnell

All rights reserved. No part of this may be reproduced in any form or by any means without written permission from the copyright holder. These designs & instructions are for personal non-commercial use by the original purchaser only and are protected under US & International Laws.

Left Border

Repeat the same process for embroidering the Left Borders.

1. Line up first stitch
2. Sew Placement line without thread (for straightness)
3. Embroider the words

Fabric Position: Top of the Quilt is positioned at the at the **BOTTOM** of the hoop for all 3 hoopings. The quilt top is upside down!

Open 4 Left Border

Open #1 prayers are planted and

First stitch: the needle is positioned at the center crosshair on the **Left Border**. See green start arrow in **Example #1**. The quilt is upside down!



start

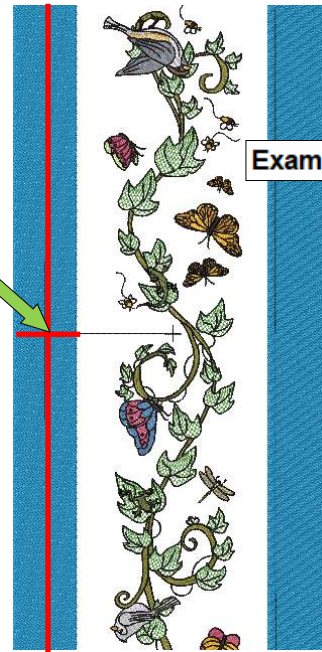

Example #1.

Open #2 Gardening is where

First stitch: the needle is positioned at the center bottom of the "p" in the word prayers. See green start arrow in **Example #2**. That location on the "p" represents the bottom of the lower case letters!

The words will embroider above the previously embroidered words.



start



Example #2.

(the quilt is upside down)

Open 3 miracles are grown.

First stitch: the needle is positioned at the center bottom of the "d" in the word "and." See green start arrow in **Example 3**. The words will embroider below the previously embroidered words.



(the quilt is upside down)

start



Example #3.

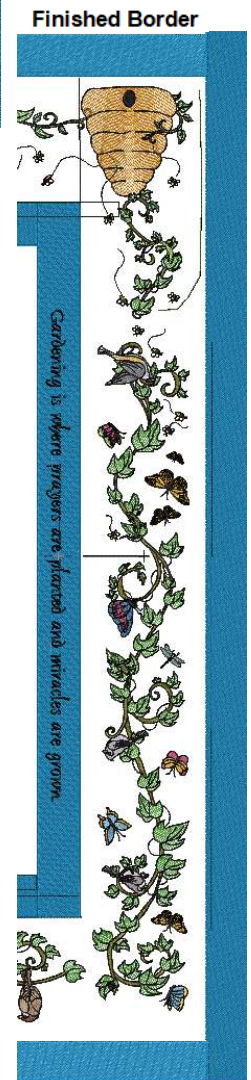

Finished Border

Picture shows quilt upside down

Ready to quilt!

Please check my YouTube Channel / claudiascreationsaz for instructions on how to **Block the Quilt** (process to remove the starch, soften the left in stabilizer and squaring it up).

Copyright © 2019 Claudia Dinnell

All rights reserved. No part of this may be reproduced in any form or by any means without written permission from the copyright holder. These designs & instructions are for personal non-commercial use by the original purchaser only and are protected under US & International Laws.